



Moldex3D
MOLDING INNOVATION

CAE模流分析技術在模具異 型水路設計之應用

科盛科技

大綱

- > 模具冷卻系統目的與涵義
- > 冷卻系統設計品質影響性
- > 何謂異型水路
- > 異型水路設計評估關鍵
- > 異型水路案例應用

模具冷卻系統目的與涵義

設計冷卻系統關鍵考慮因素?

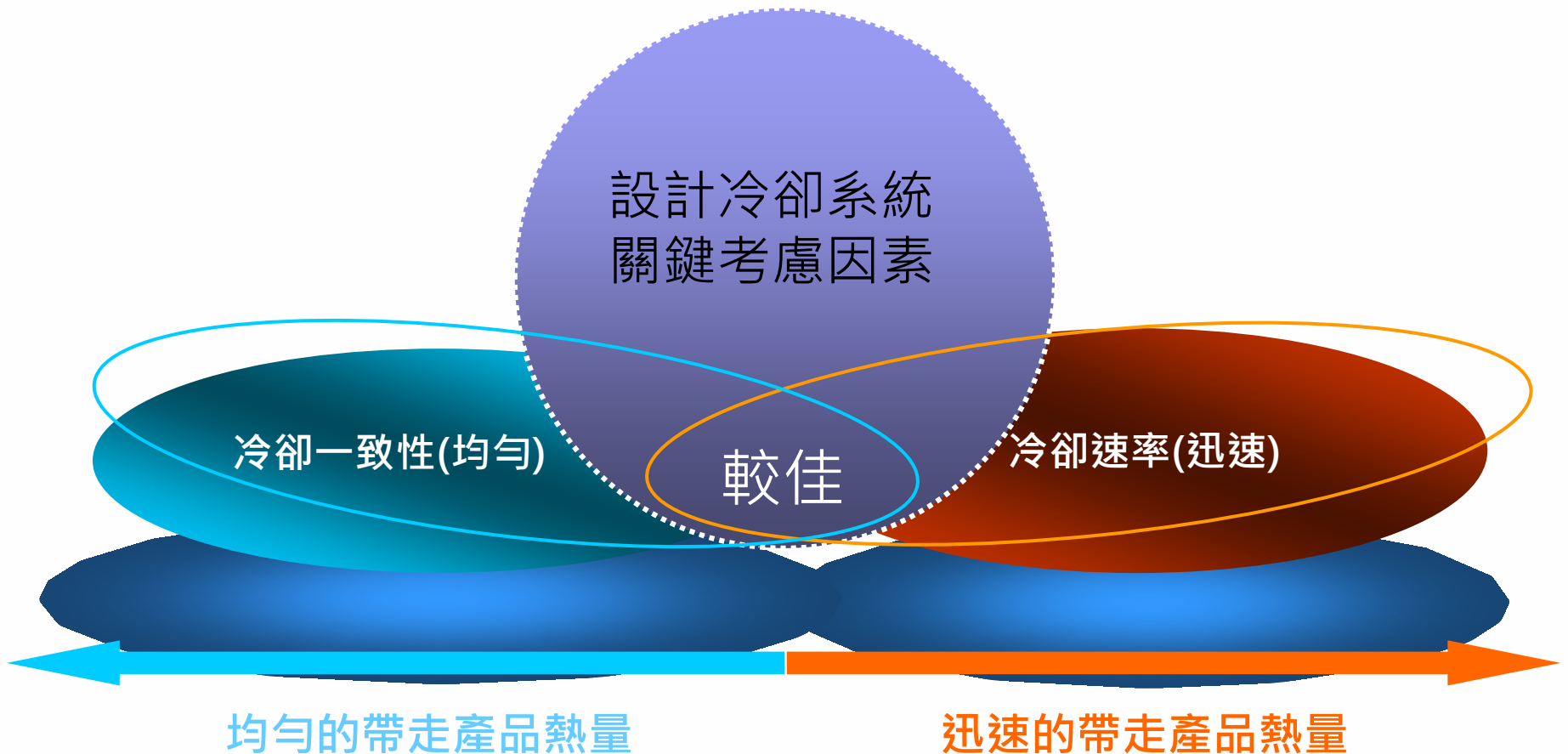

單一成型週期內的模溫變化

射出成型程式

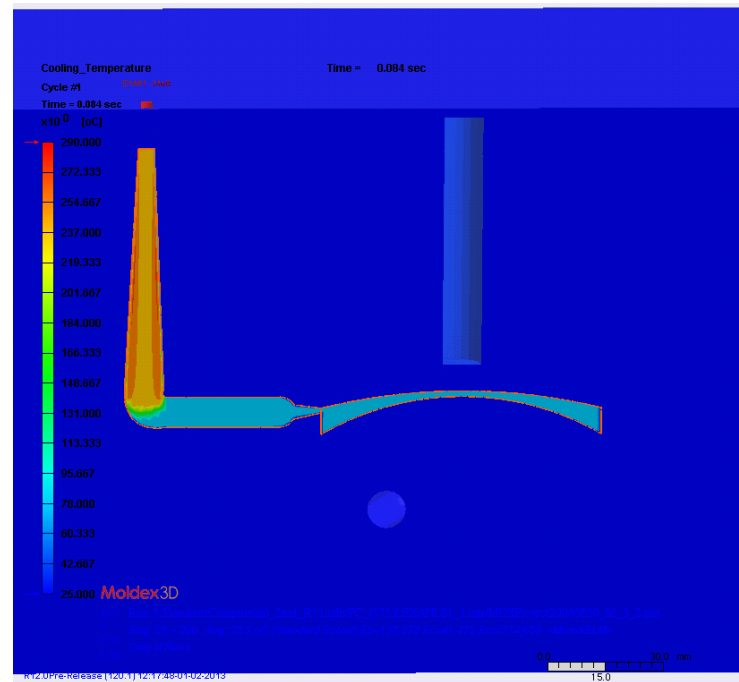
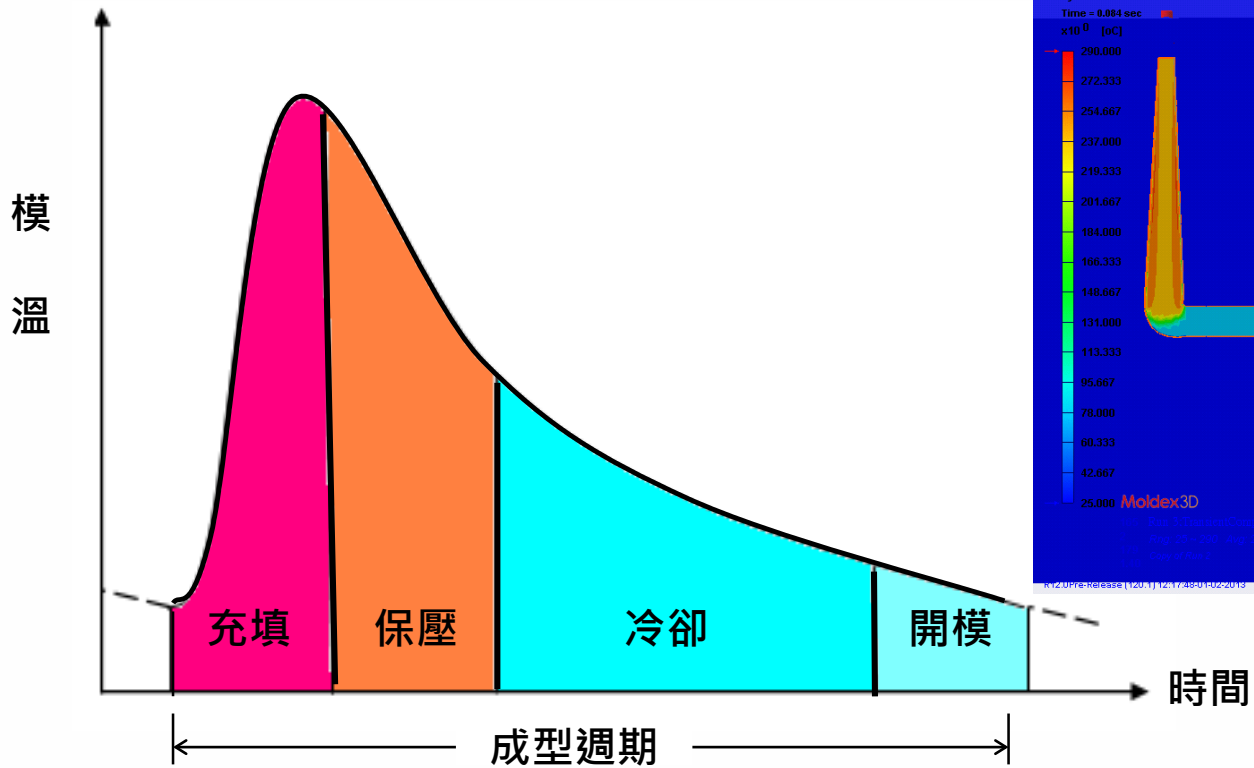
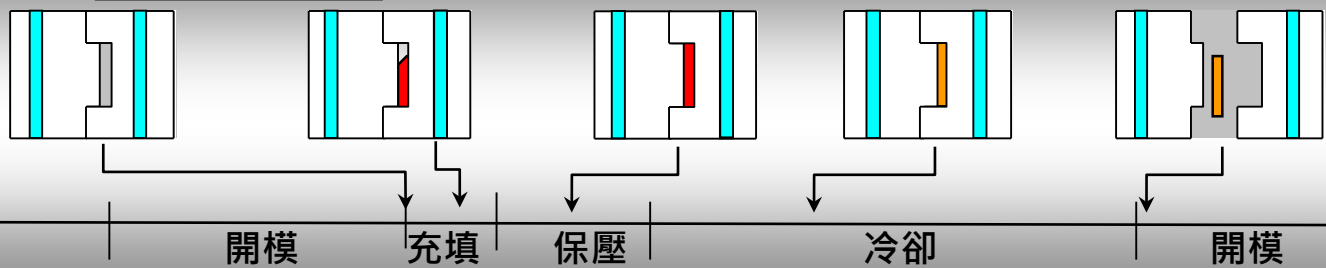

連續成型週期的模溫變化歷程

良好穩定的週期

真實模溫變化 T

成型週期

成型初始階段

穩定成型階段

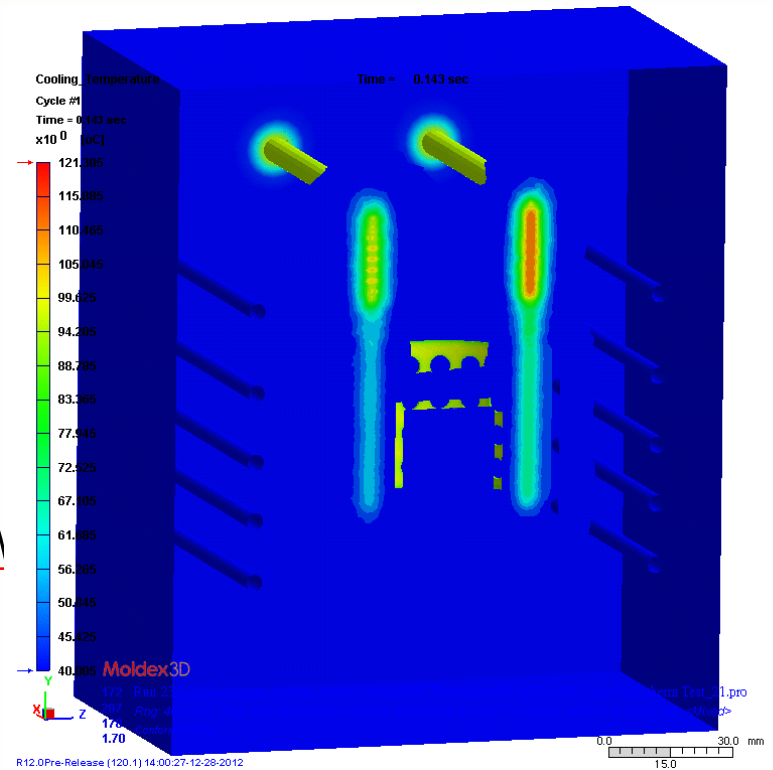

冷卻系統設計概念

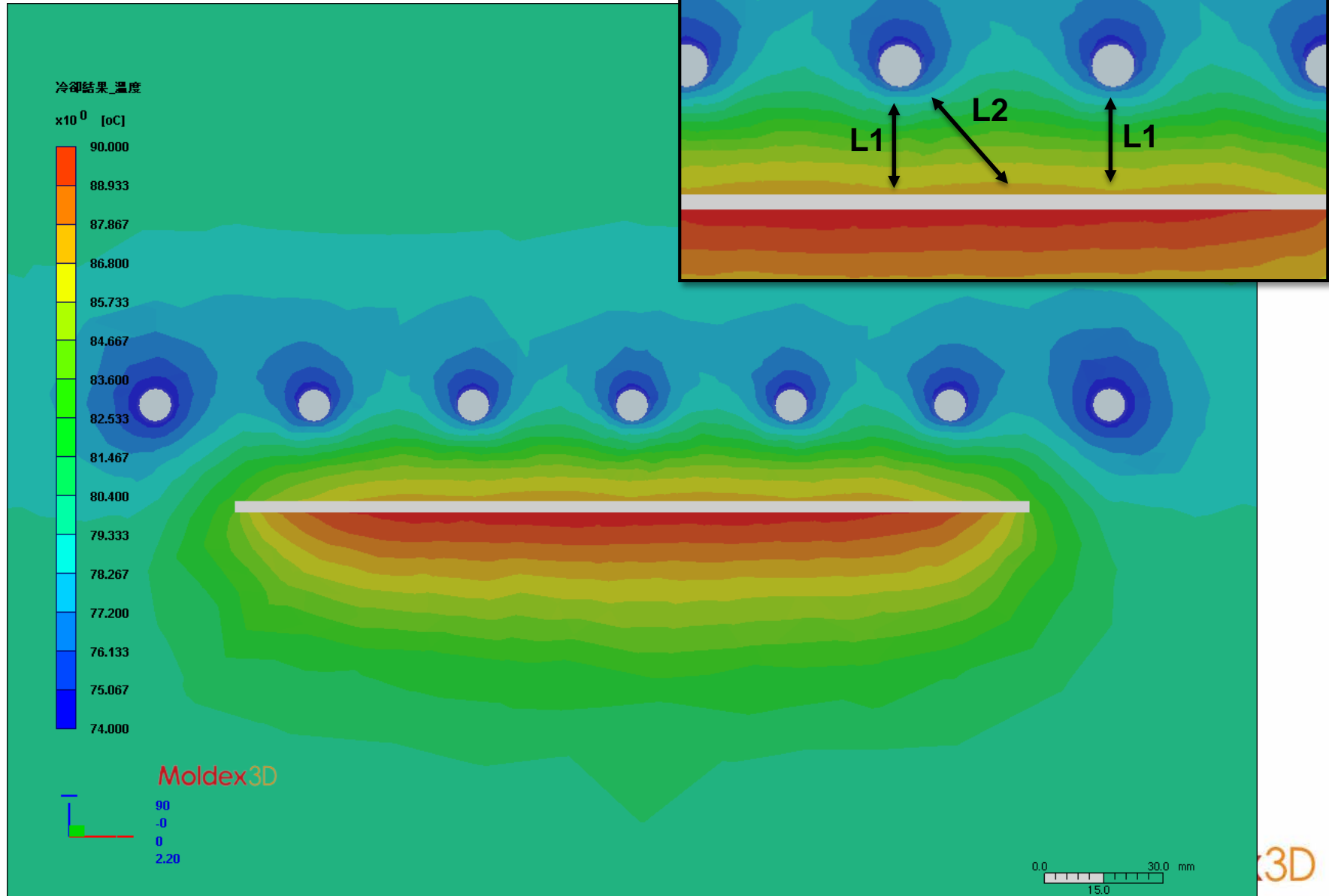

異型水路簡介

- > 什麼是異型水路？
 - 依照產品外型所設計的冷卻水路
- > 為何要使用異型水路？
 - 為了增加冷卻效率。使用異型水路時，產品的冷卻率差異可以最小化
 - 為降低成型時間與成本
 - 為了提升產品品質

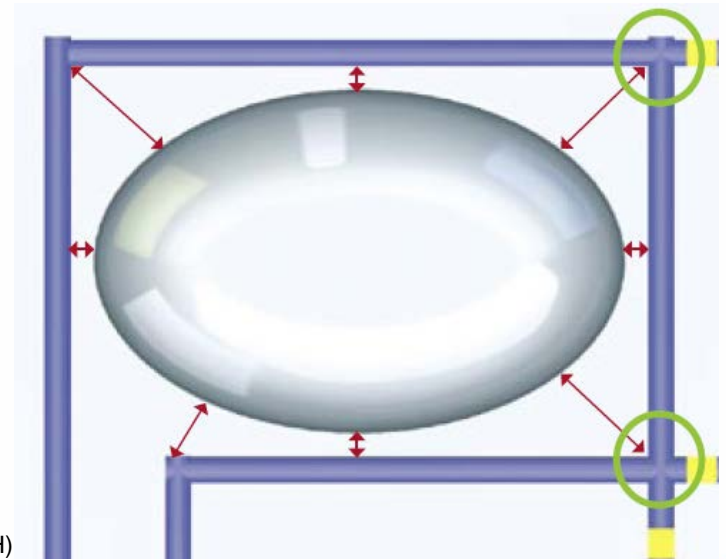

Source: EOS whitepaper, Siegfried Mayer (EOS GmbH)

異型水路簡介

> 何時使用異型水路?

- 當產品幾何複雜時，有些積熱區傳統水路無法到達，因此無法有效散熱。這時就需要異型水路。

> 如何製造異型水路?

- 傳統的製造方式很難製造異型水路。
- 雷射燒結法
- 真空燒焊法。

異型水路有何優點？

- > 在射出成型過程中使用異型水路可以幫助：
 - 改善產品品質如凹痕及翹曲
 - 降低成型時間
 - 加強積熱區的散熱效率
- > 異型水路設計評估關鍵
 - 產品溫度分布均勻性
 - 冷卻水管壓力損耗
 - 冷卻水路進出口溫差
 - 週期時間
 - 變形改善



水管壓降設定

- > 可定義壓降為水管邊界設定
- > 輸出所需要的水管流速及壓降於記錄檔內

> 效益

- 估計所需要的模溫機尺寸

```
<Cooling_Channel_1>
Coolant Flow Rate      = 1.22e+001 cc/sec
Coolant Pressure       = 1.00e-001 bar
<\Cooling_Channel_1>
<Cooling_Channel_2>
Coolant Flow Rate      = 4.20e+001 cc/sec
Coolant Pressure       = 1.00e+000 bar
<\Cooling_Channel_2>
```

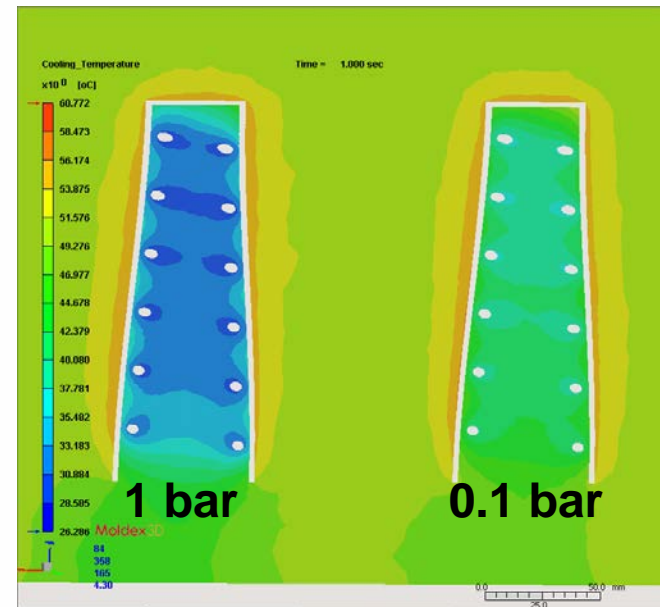
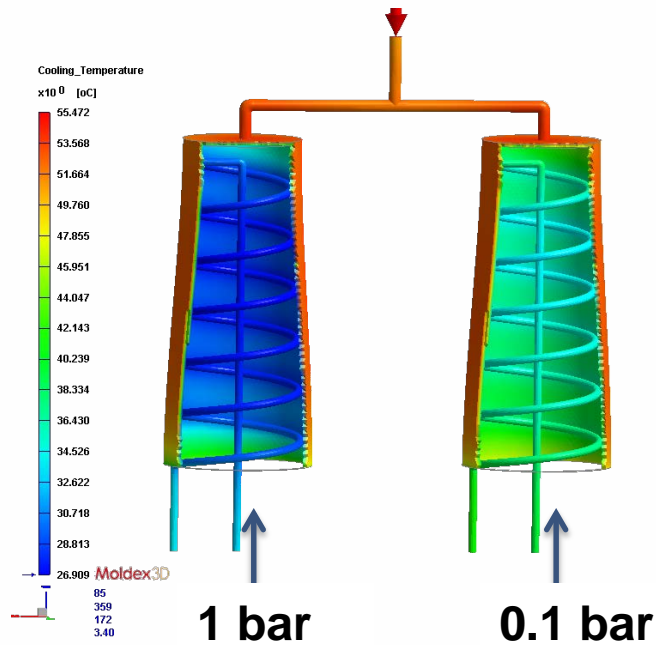

傳統溝槽式水路設計驗證

網格模型_實體模型

Coolant-1:Water

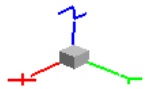
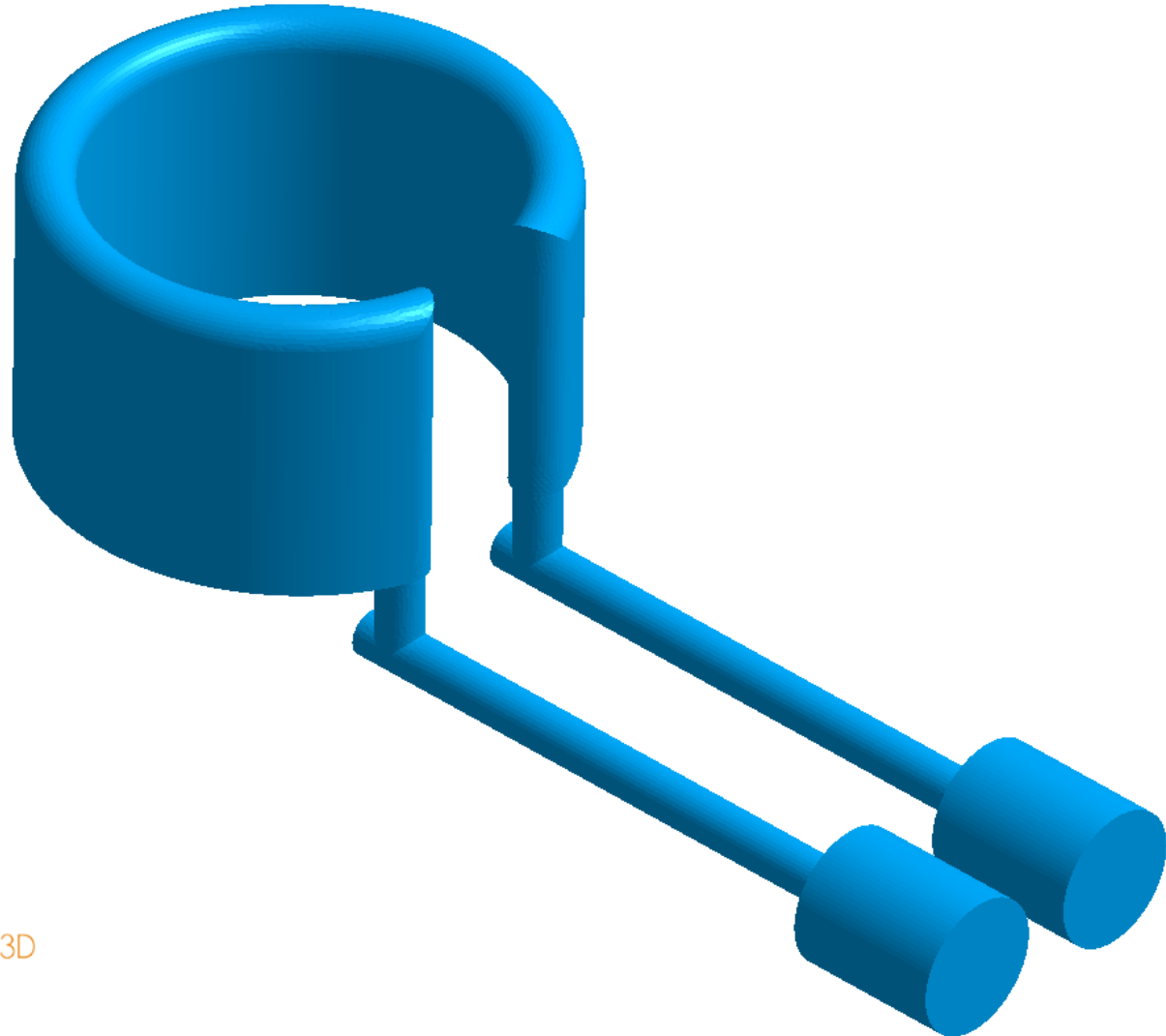

Moldex3D

54
359
133
1.90

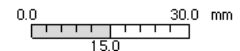

Moldex3D

驗證冷卻水路介質流速變化

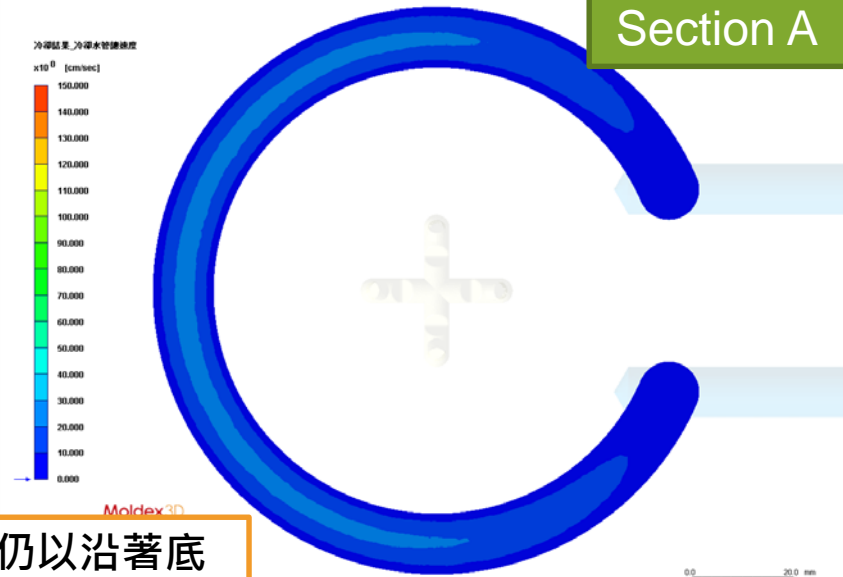
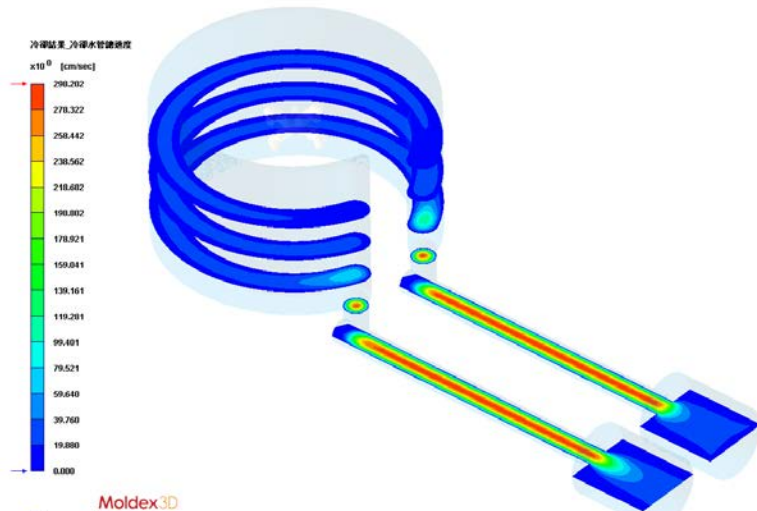

Moldex3D

Moldex3D

由速度場分布可以發現，水管內介質流動時，仍以沿著底層流動為主，上層介質流速緩慢甚至呈現死水狀態，因此上層介質在熱交換效果上成效不彰。

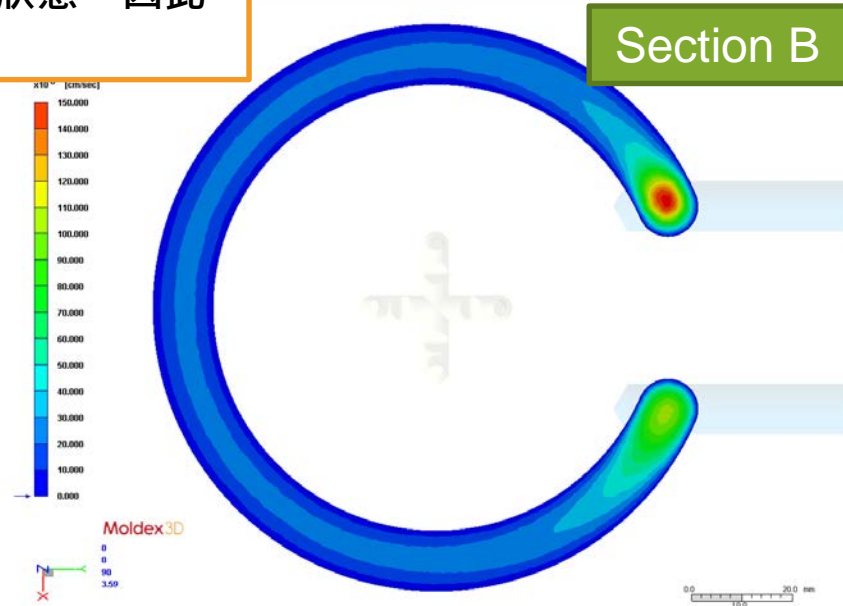
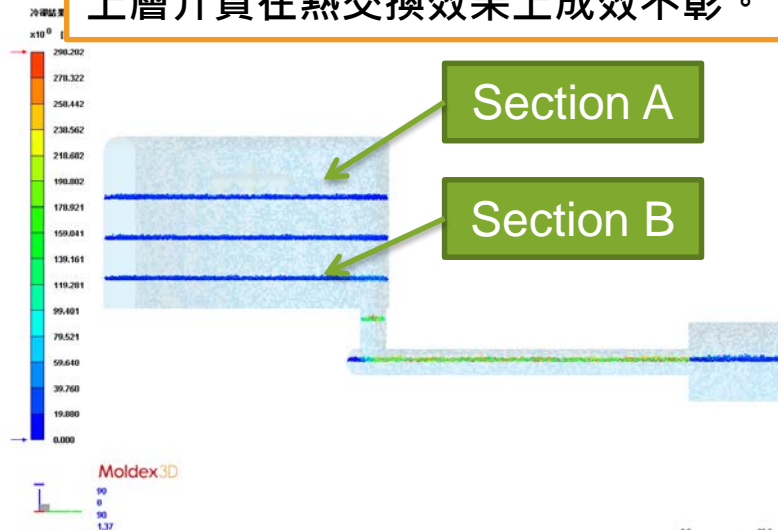

Section B

Moldex3D

Moldex3D

異型水路實際案例

網格模型_實體模型

- Part-1:ABS(CHI-MEI POLYLAC PA757)
- Cold Runner:ABS(CHI-MEI POLYLAC PA757)

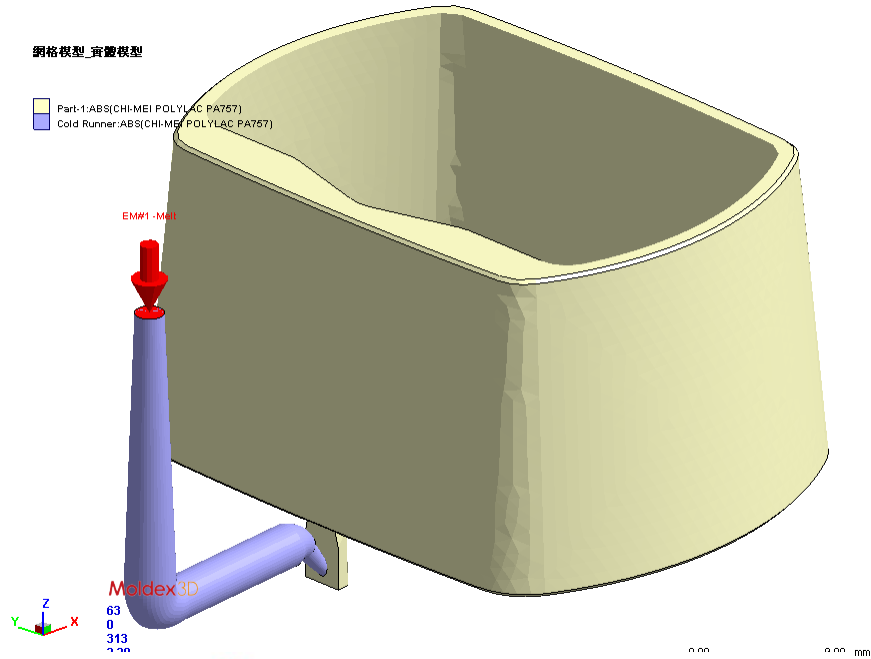

網格模型_實體模型

- Coolant-1:Water

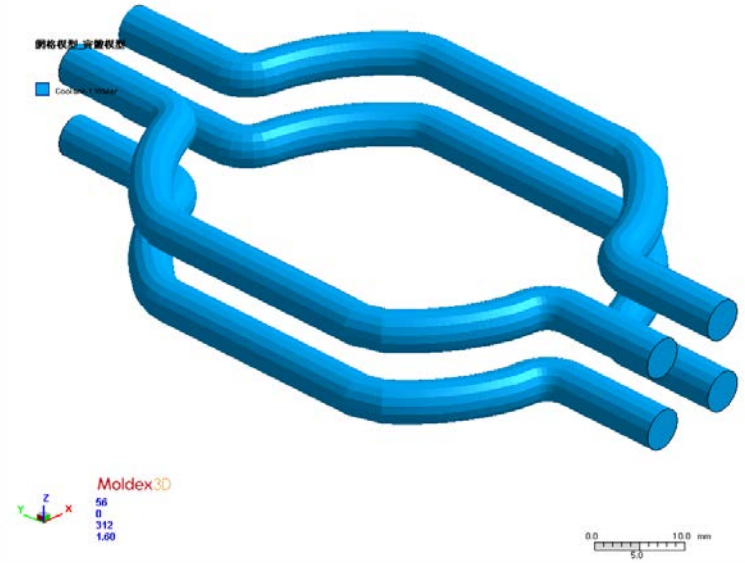

網格模型_實體模型

- Coolant-1:Water

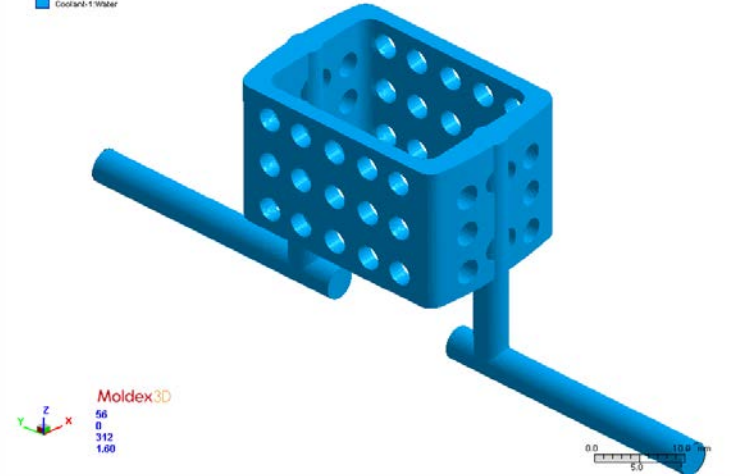

網格模型_實體模型

- Coolant-1:Water

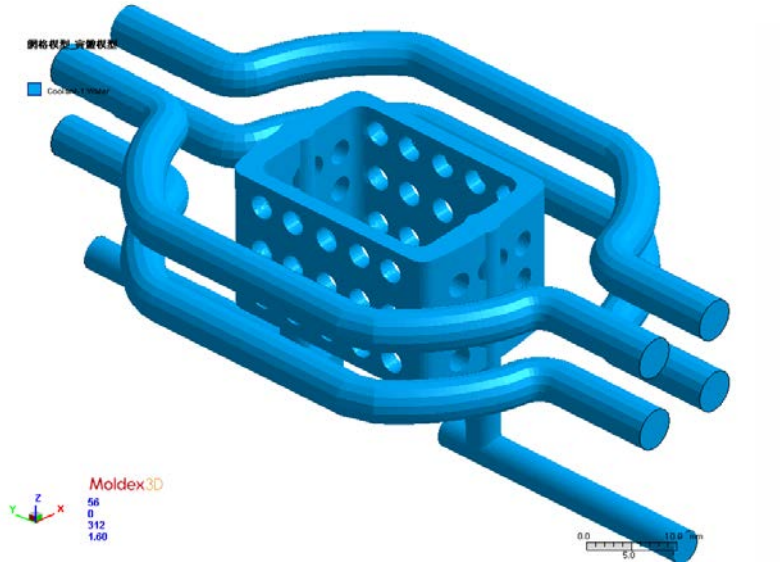

異型水路實際案例

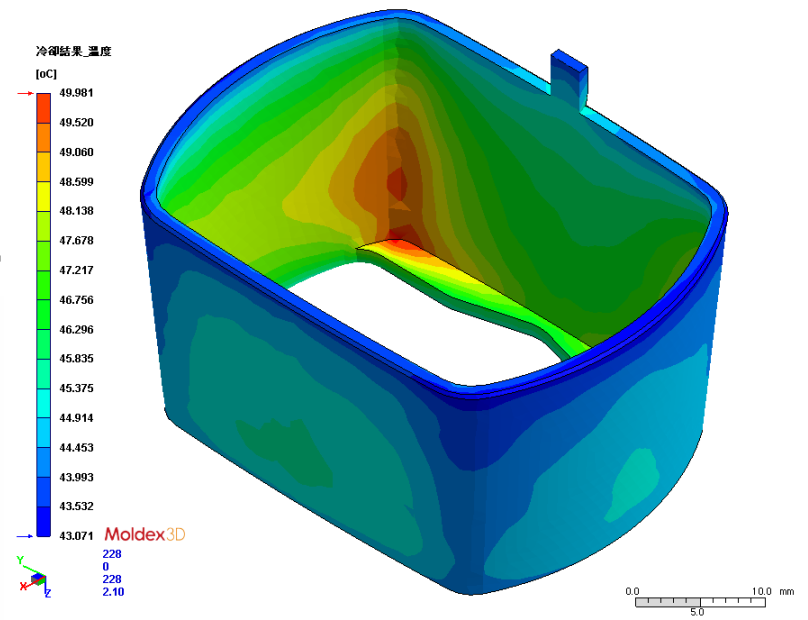
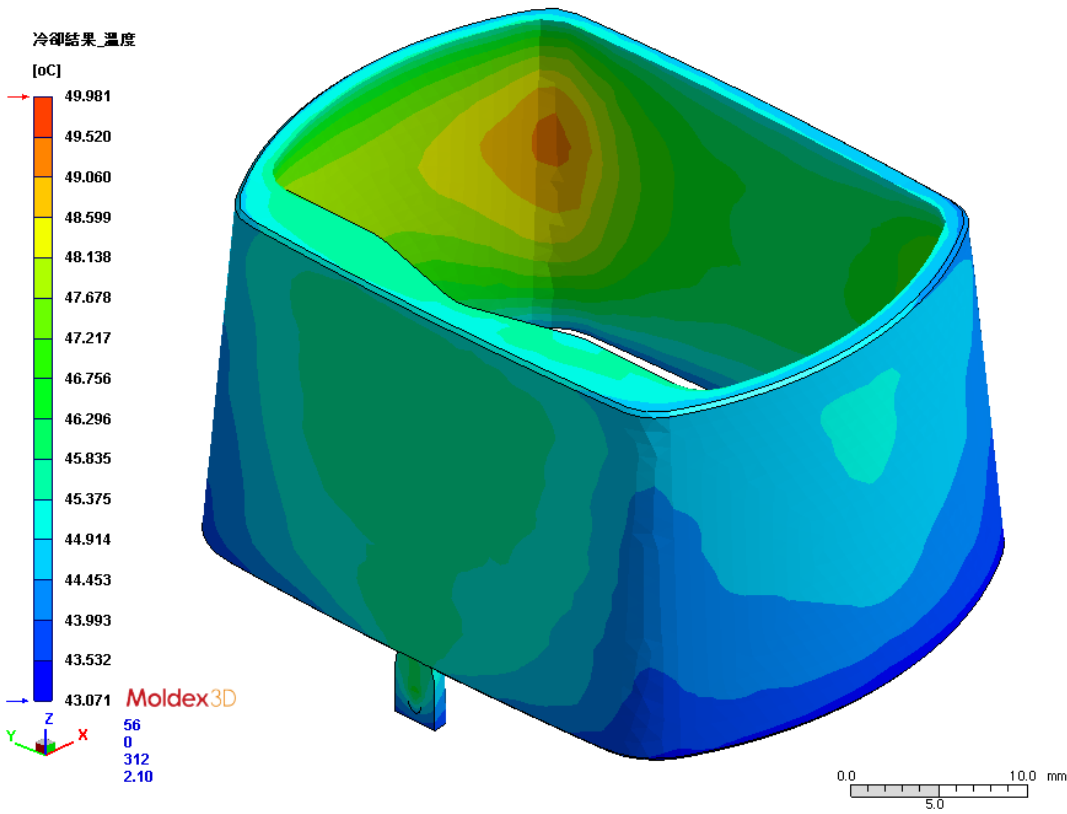

異型水路實際案例

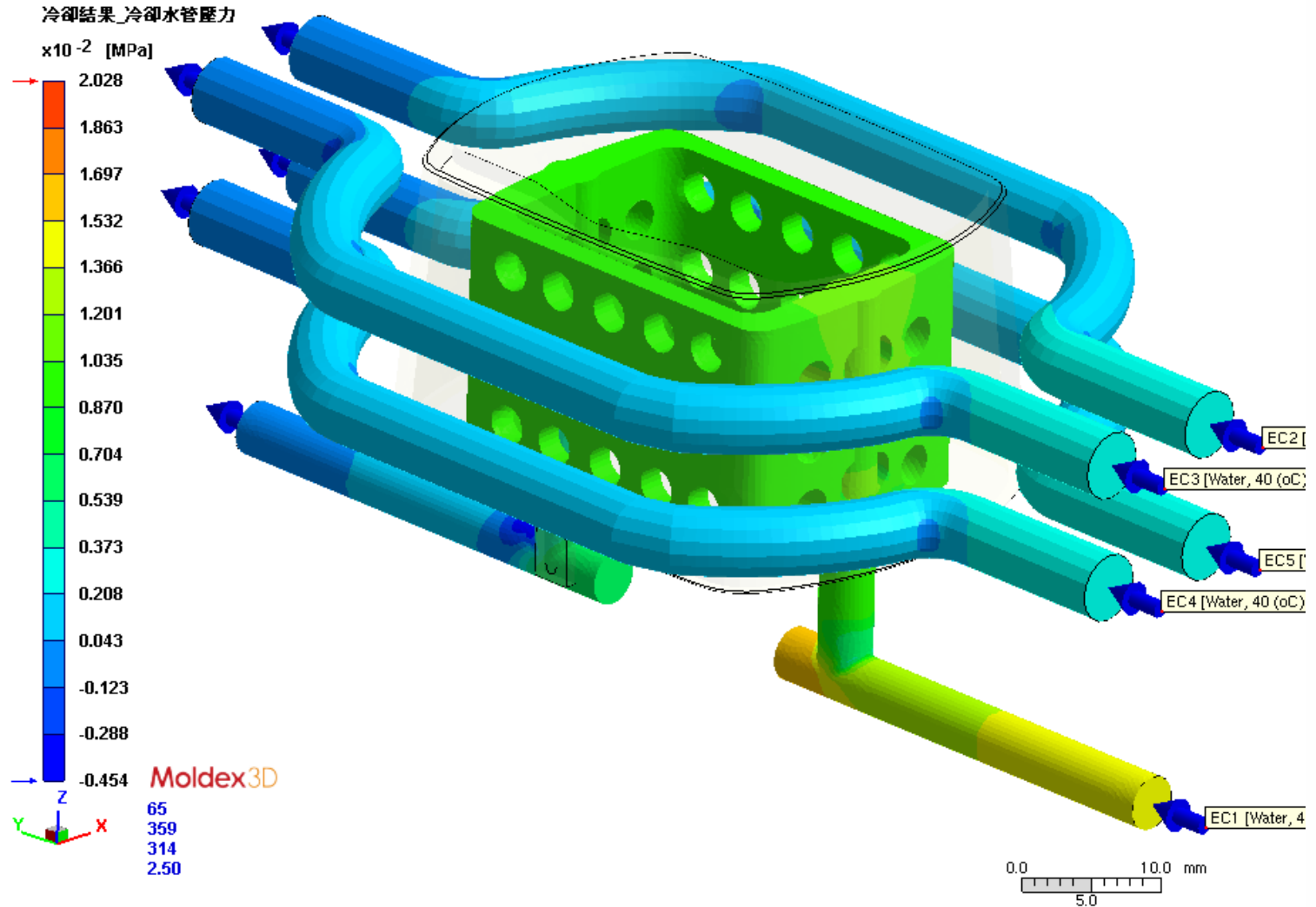

異型水路實際案例

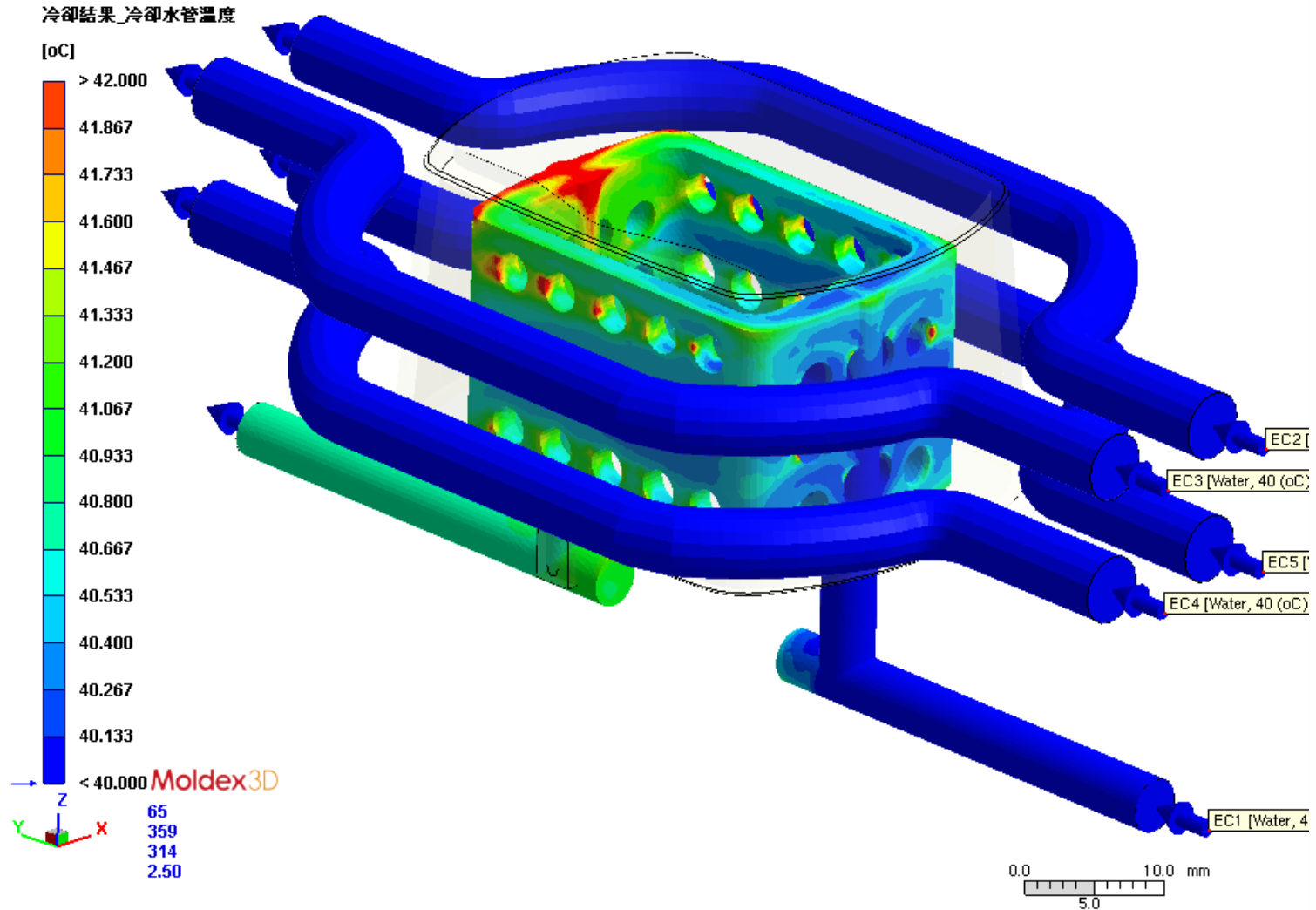

異型水路實際案例

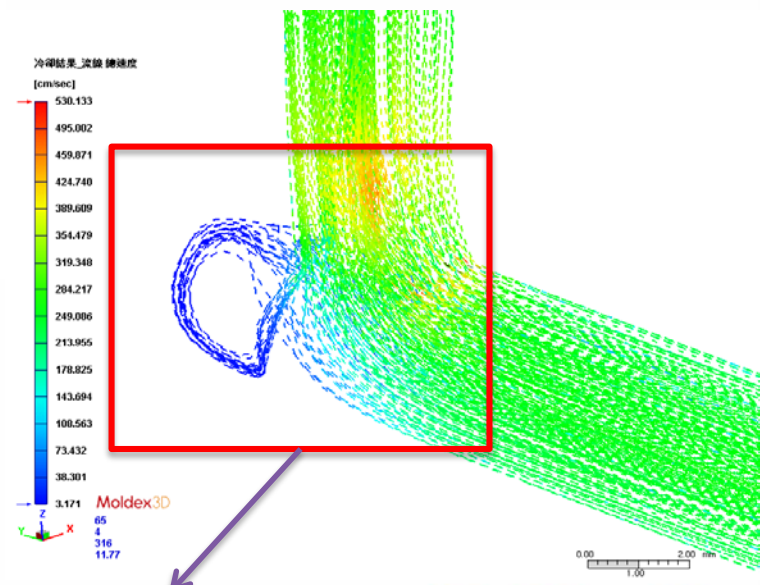
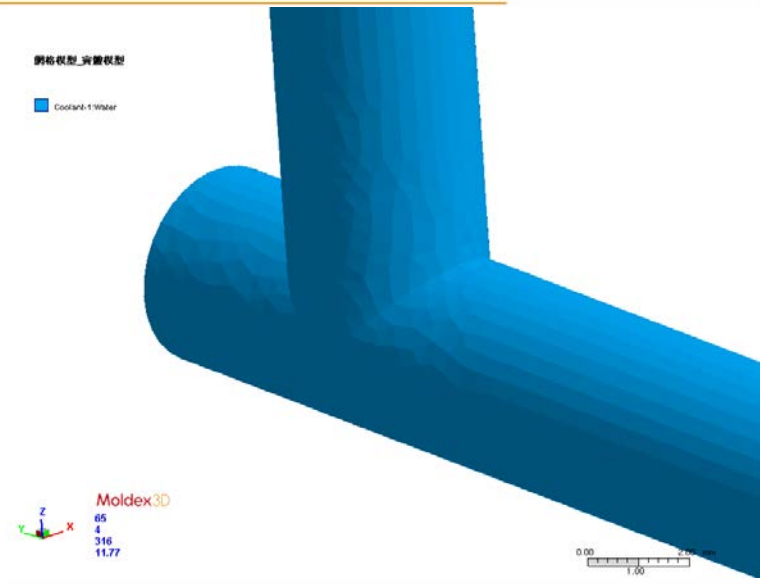
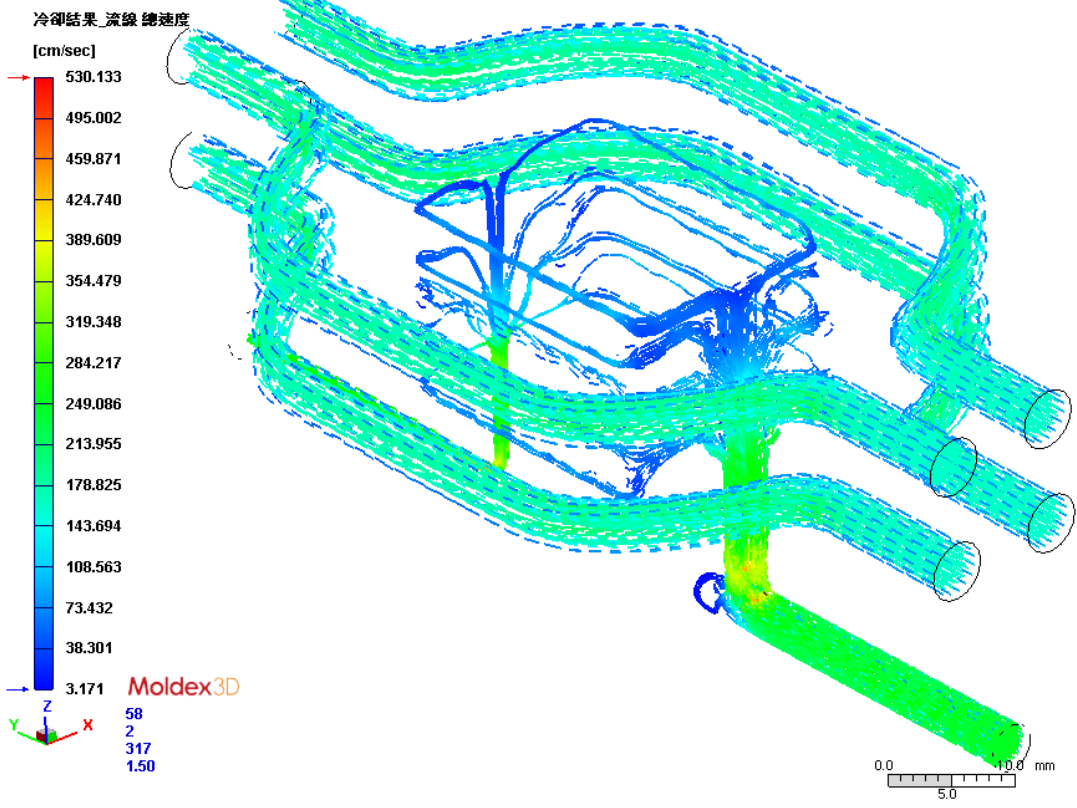

流動死水高風險處

Moldex3D

產品幾何資訊

- 產品長度： 90 mm
- 產品寬度： 90 mm
- 產品高度： 120 mm
- 產品厚度： 2 mm

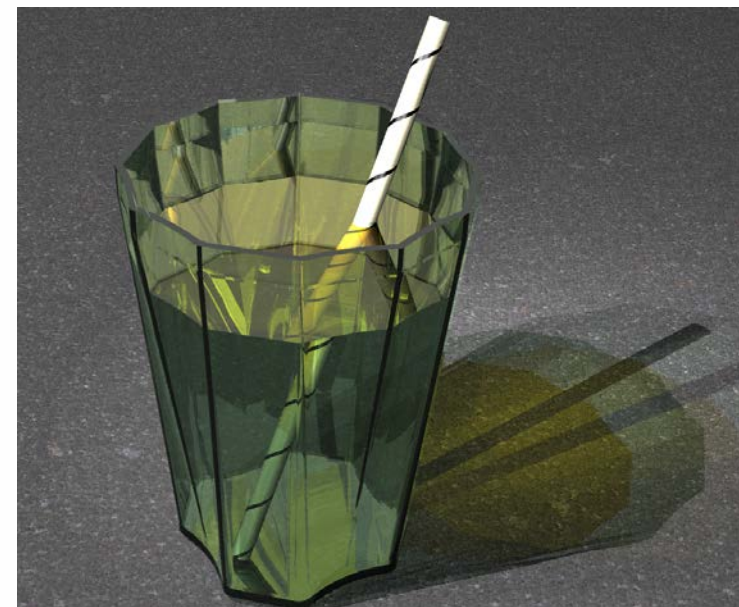
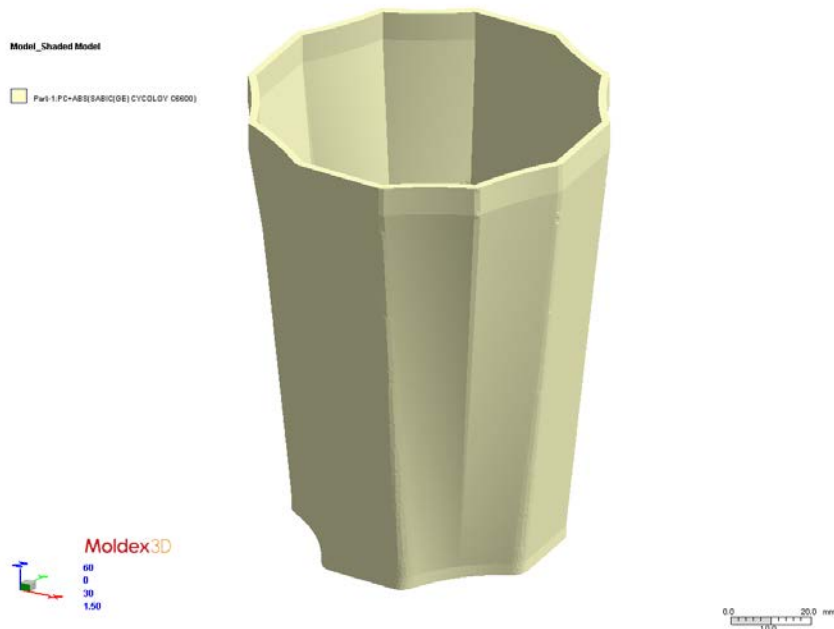
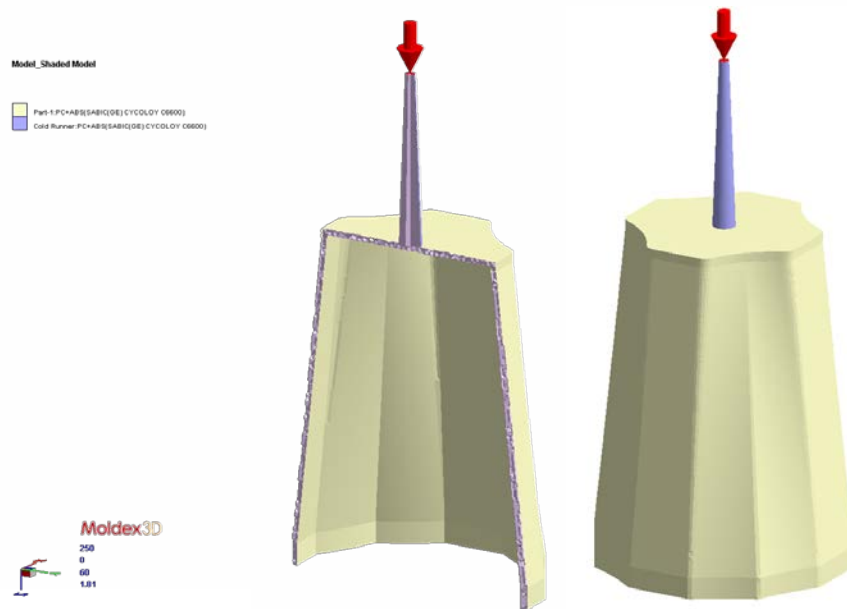

溫度感測節點分布位置

Model_Shaded Model

Part-1:PC+ABS(SABIC(GE) CYCLOLOY 06600)

Sensor Node

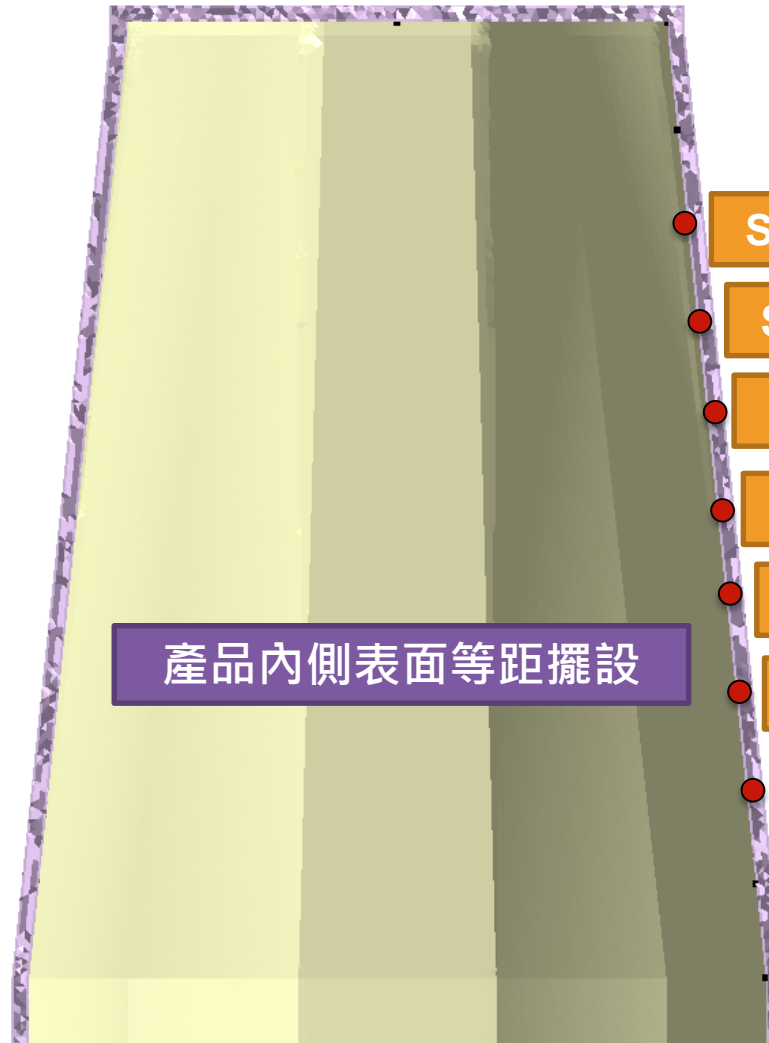

溫度感測節點

產品內側表面等距擺設

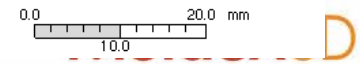
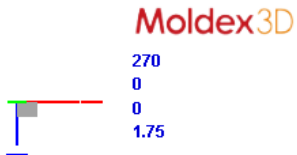

傳統水路套件設計

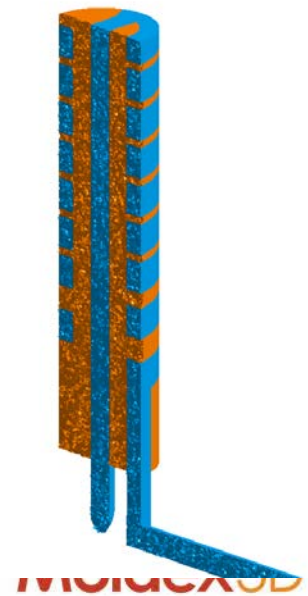
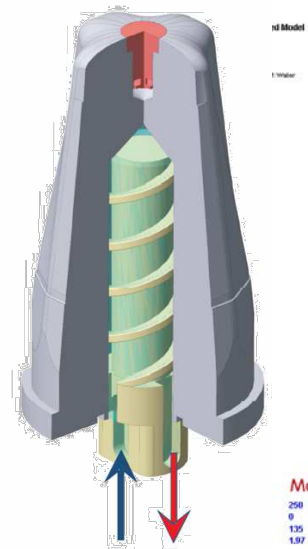
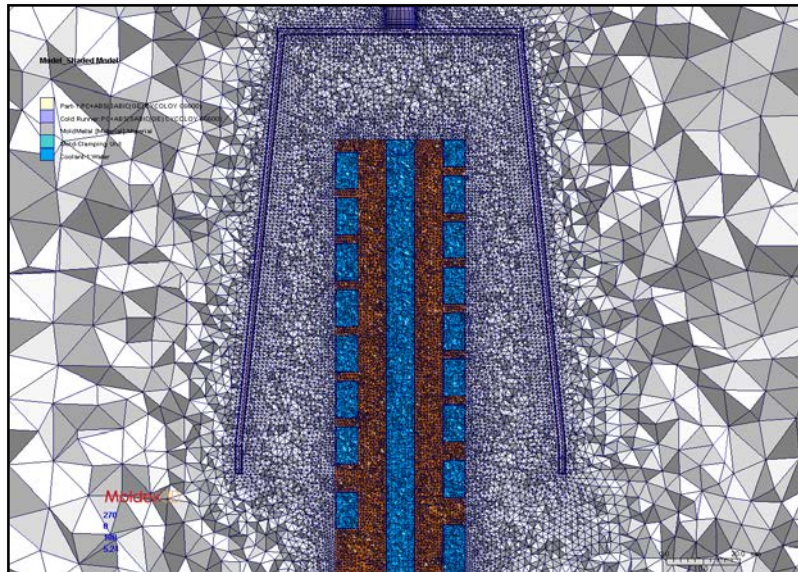
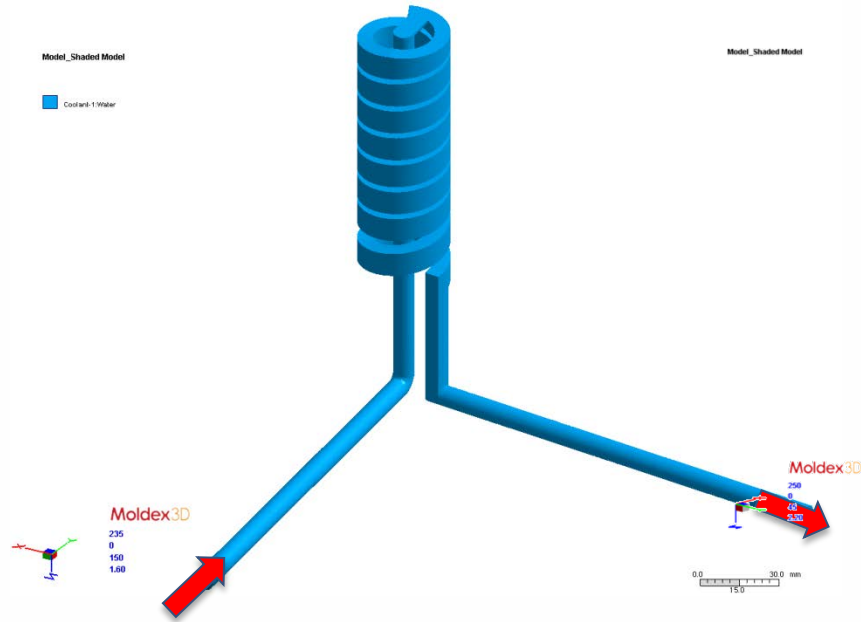

模具溫度剖面動態歷程

週期溫度分布歷程剖面動畫

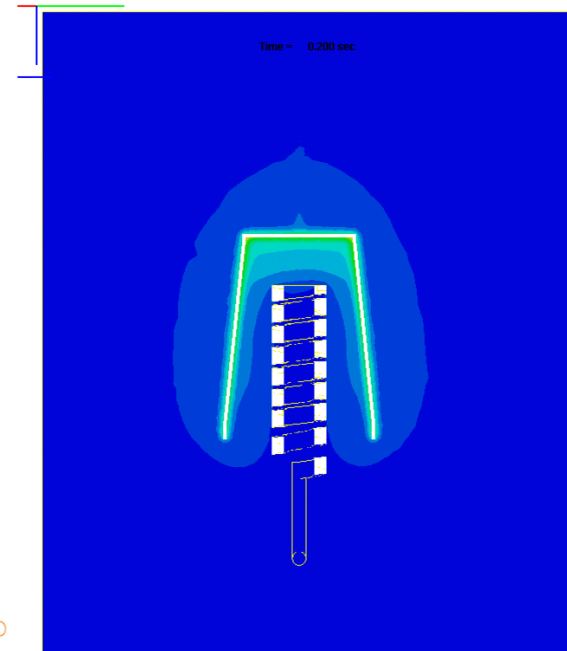
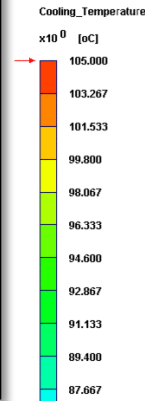
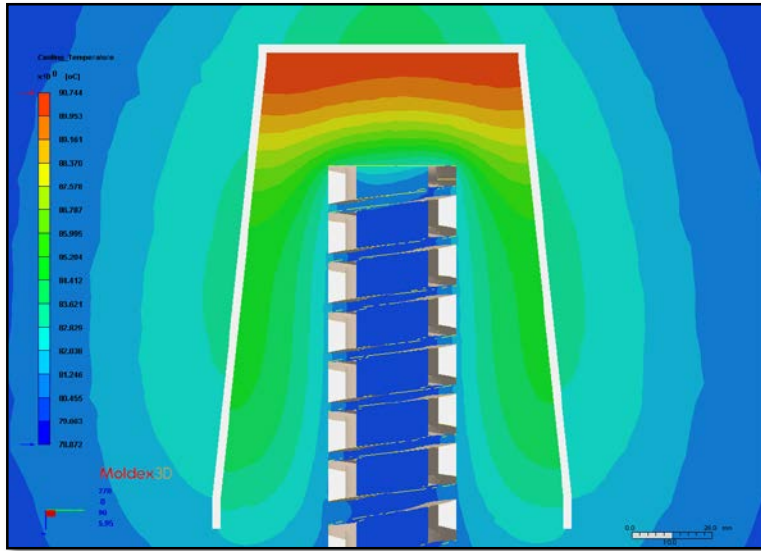

溫度顯示範圍：79~105 °C

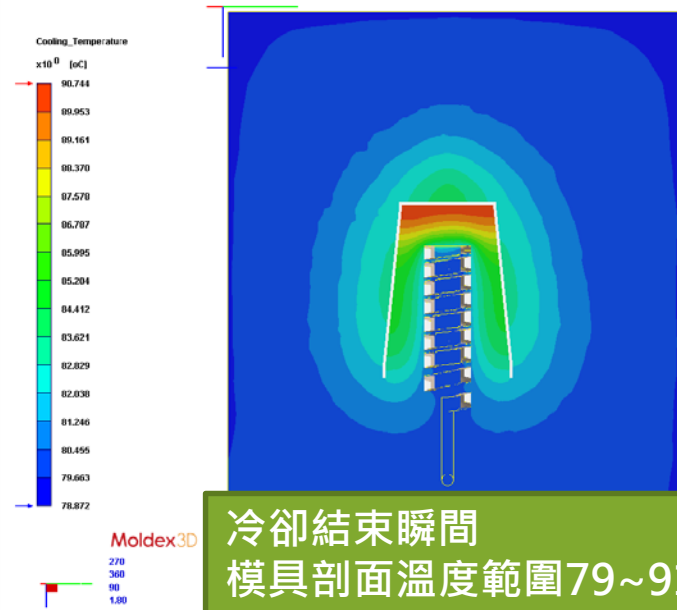

冷卻結束瞬間
模具剖面溫度範圍79~91 °C

冷卻水路速度場流線分布

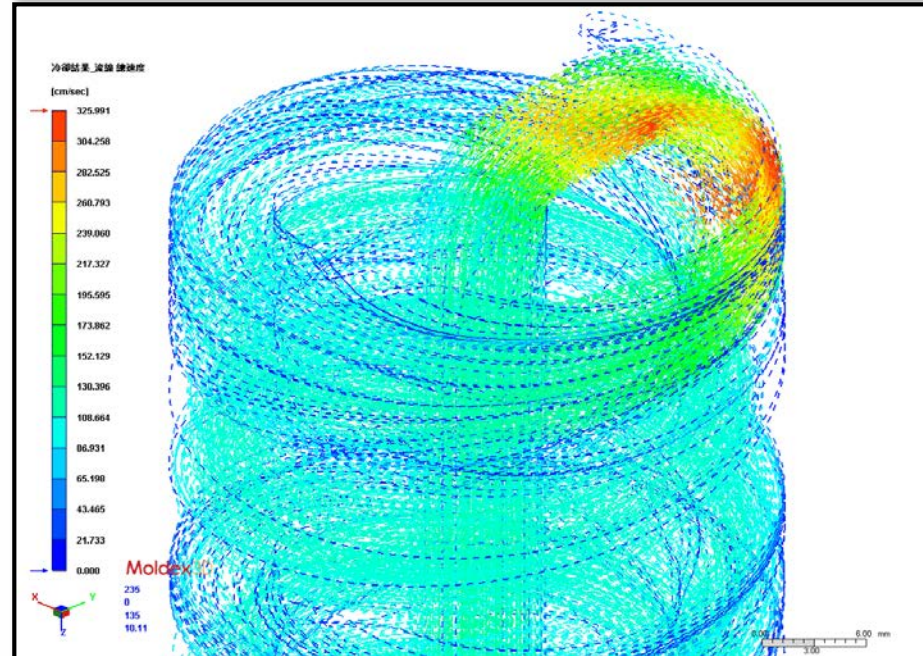
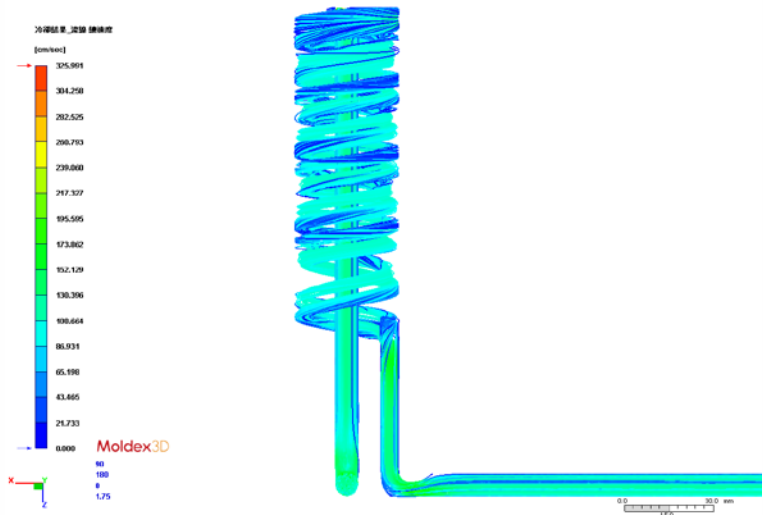
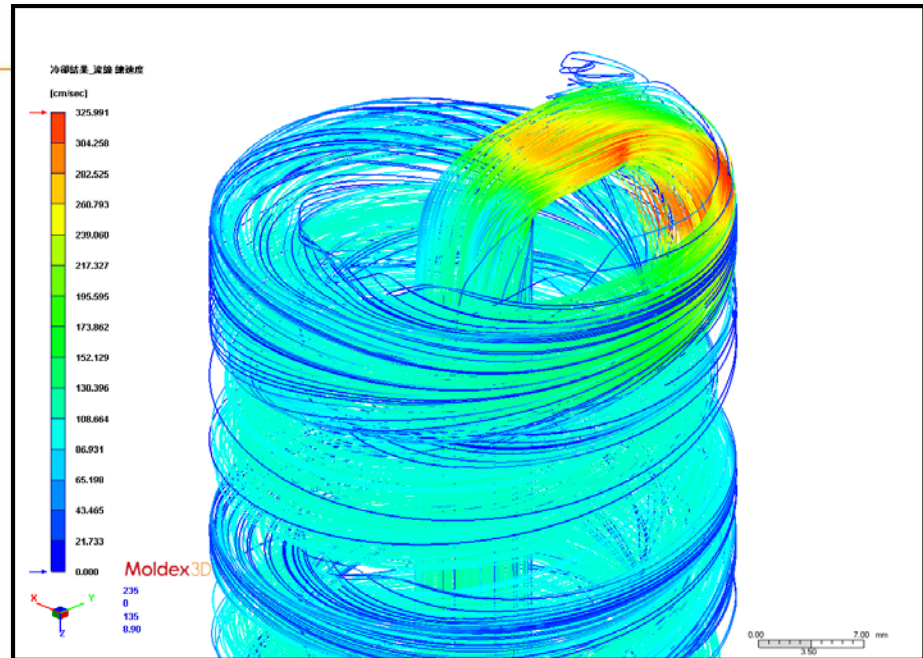
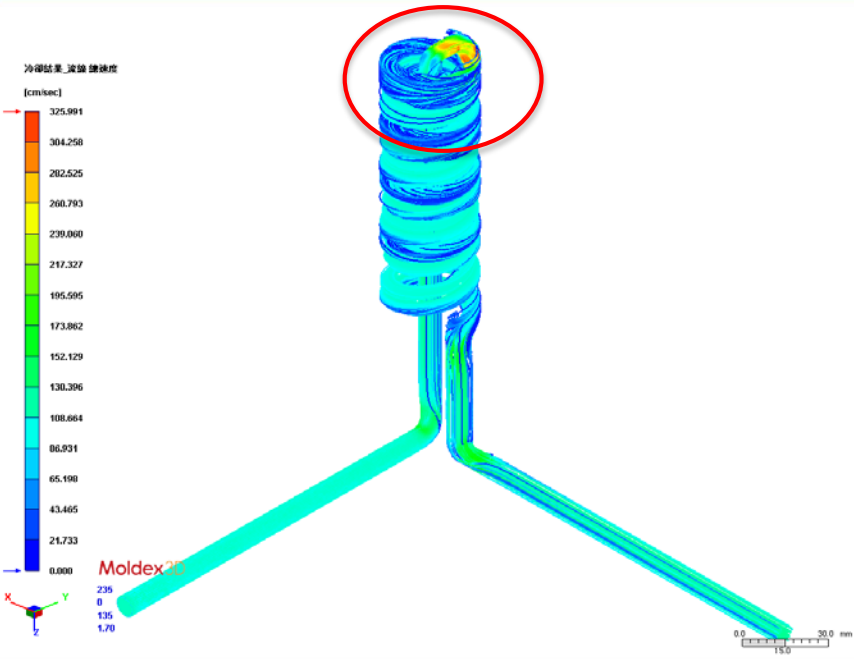

模具表面溫度歷程曲線

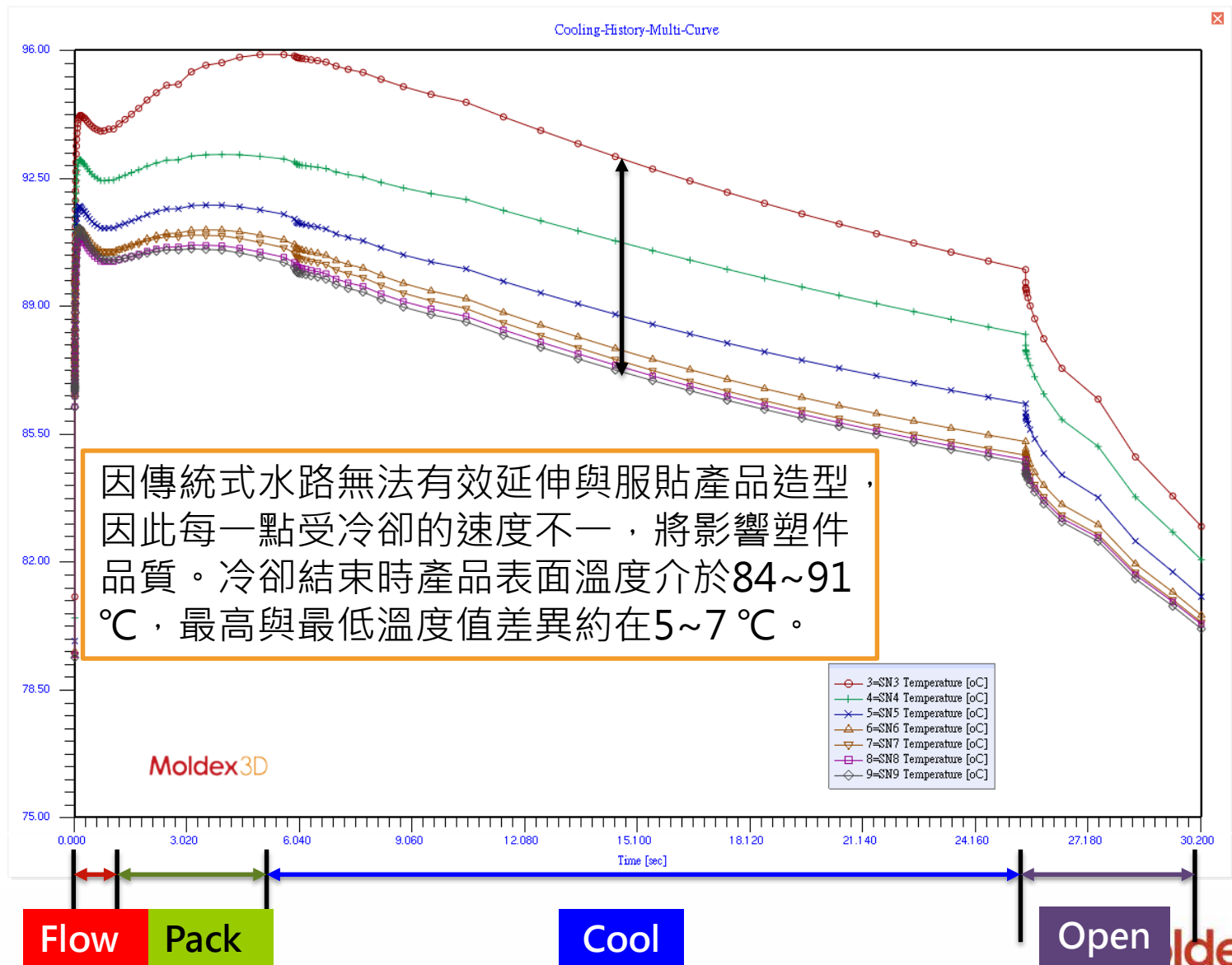

異型冷卻水路設計方式

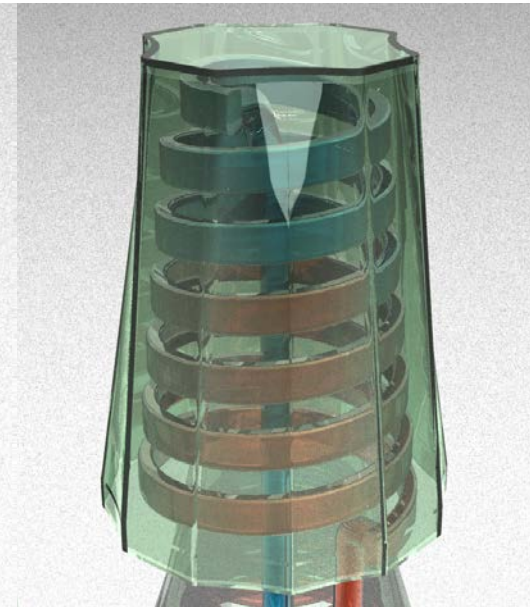
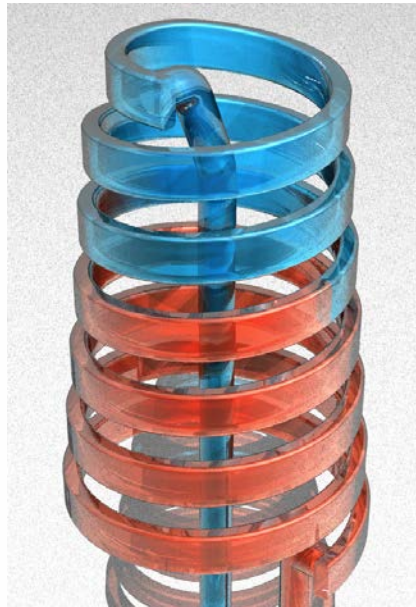
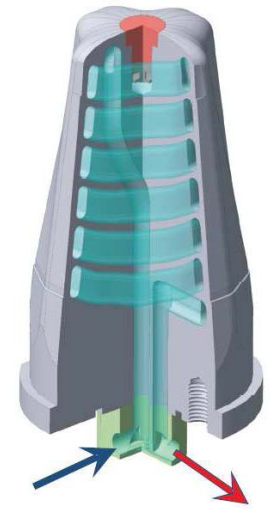
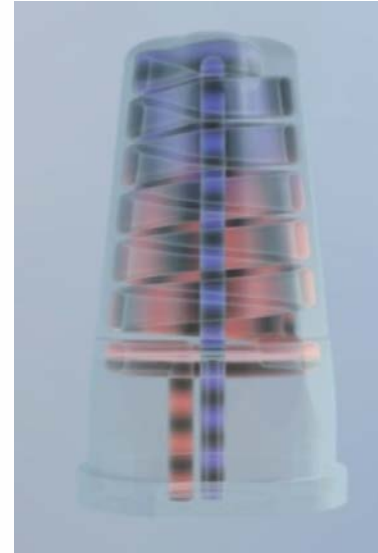
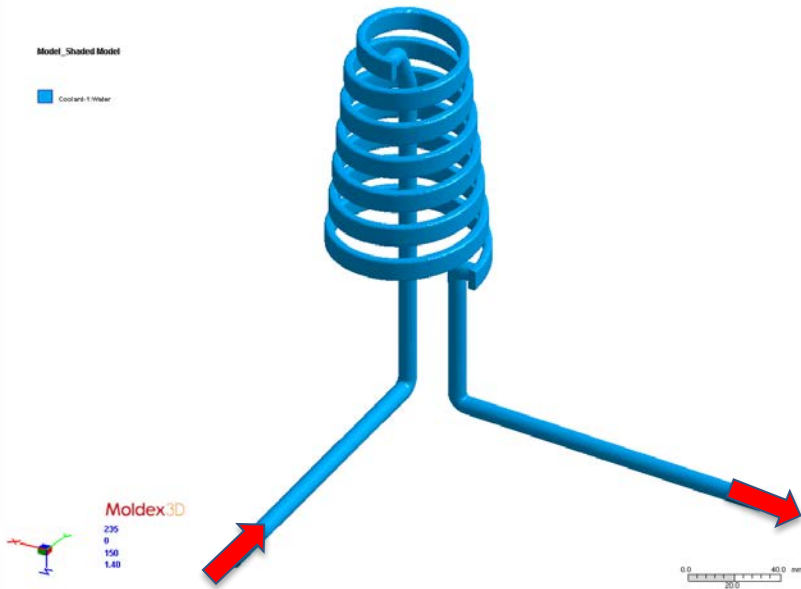

異型冷卻水路設計方式

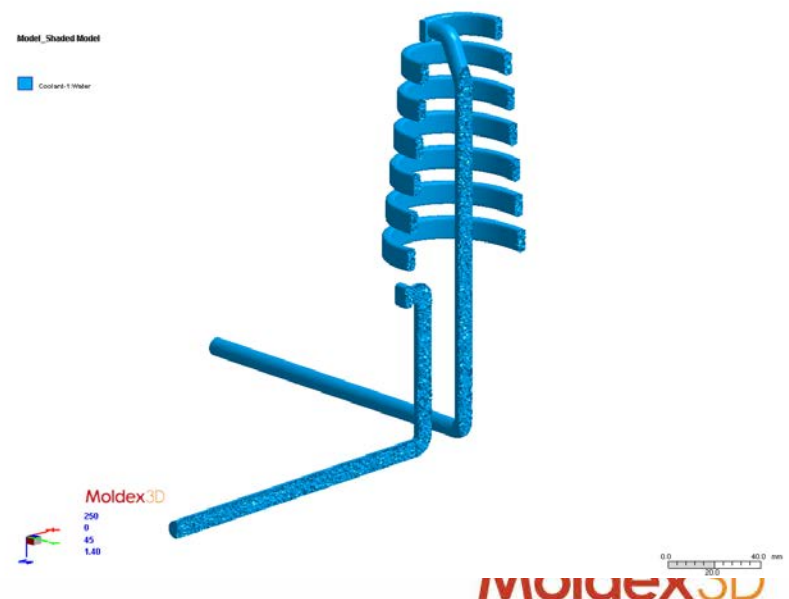
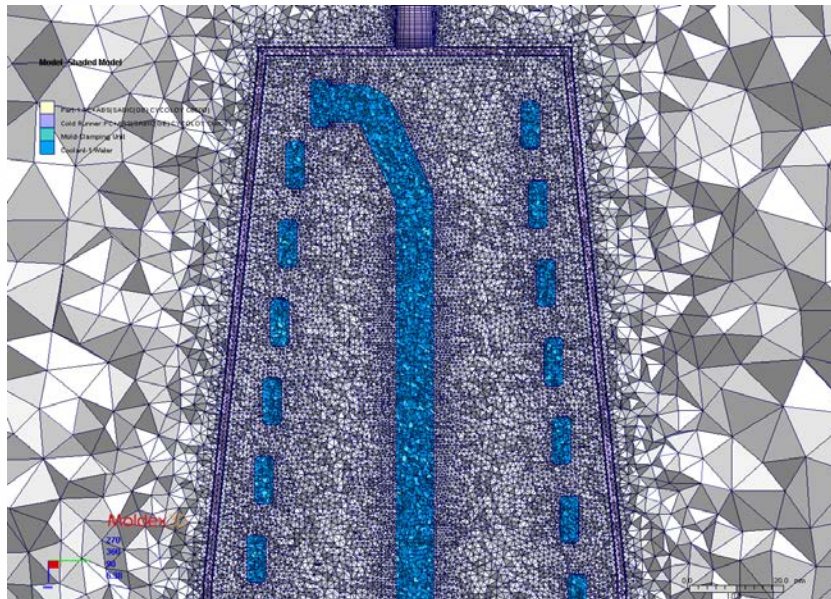
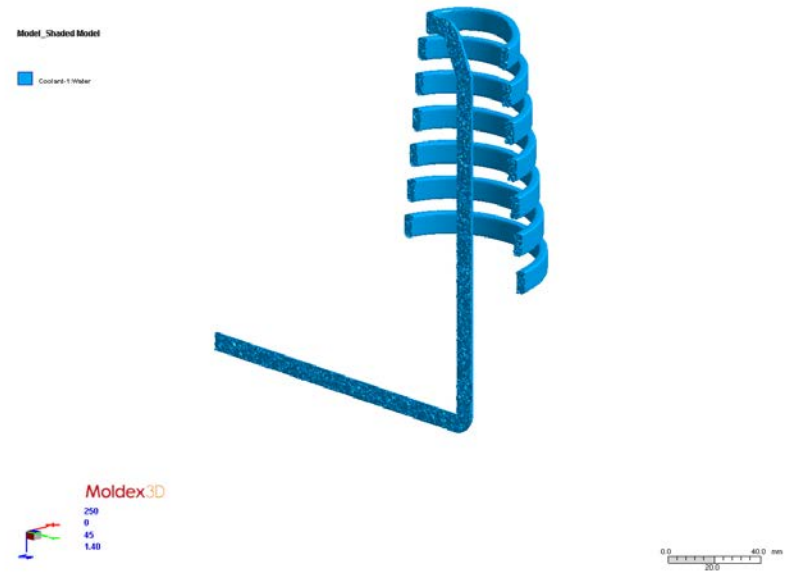
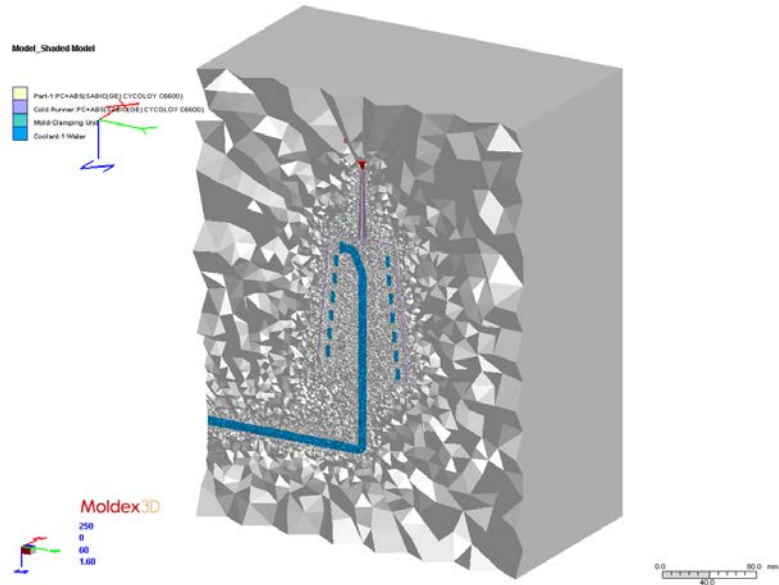

模具溫度分布

週期溫度分布歷程剖面動畫

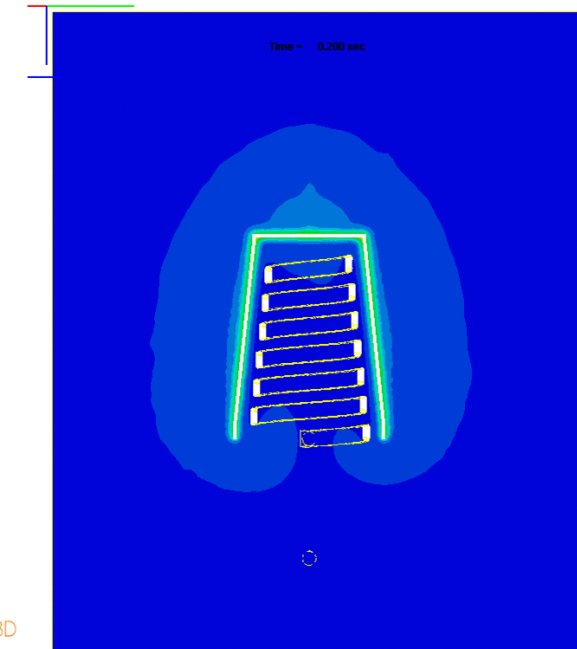
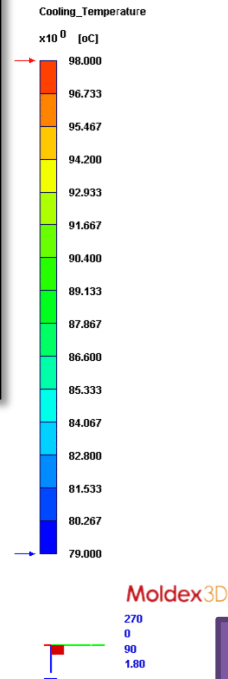
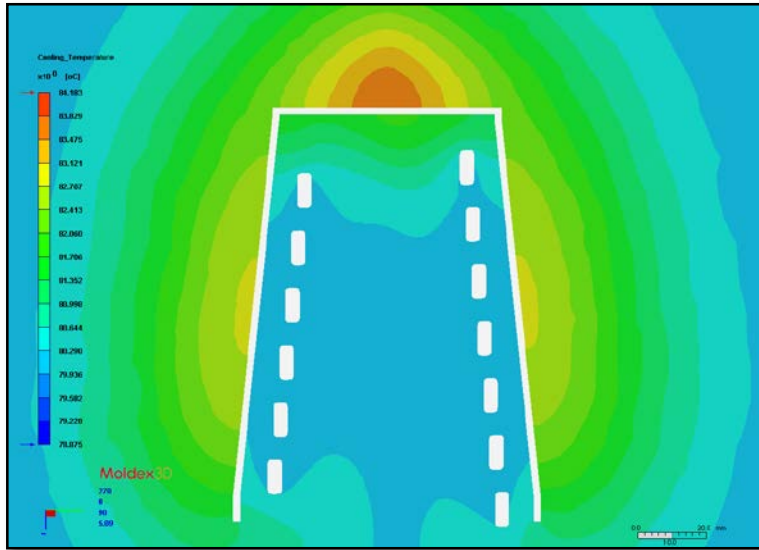

溫度顯示範圍：79~98 °C

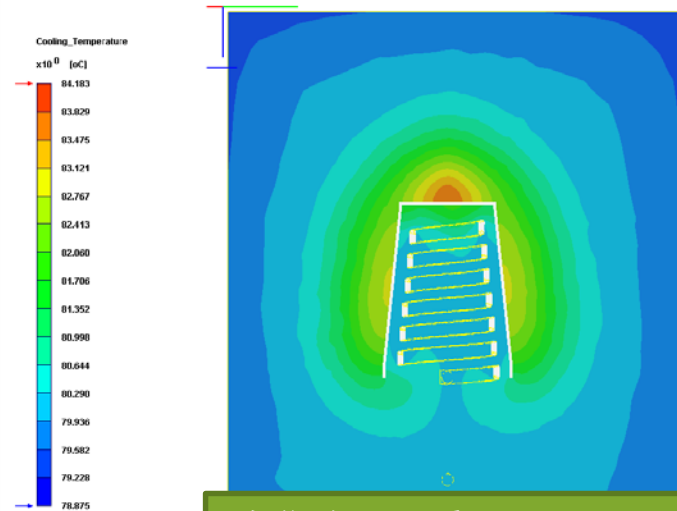

冷卻結束瞬間
模具剖面溫度範圍79~84 °C

冷卻水路溫度分布

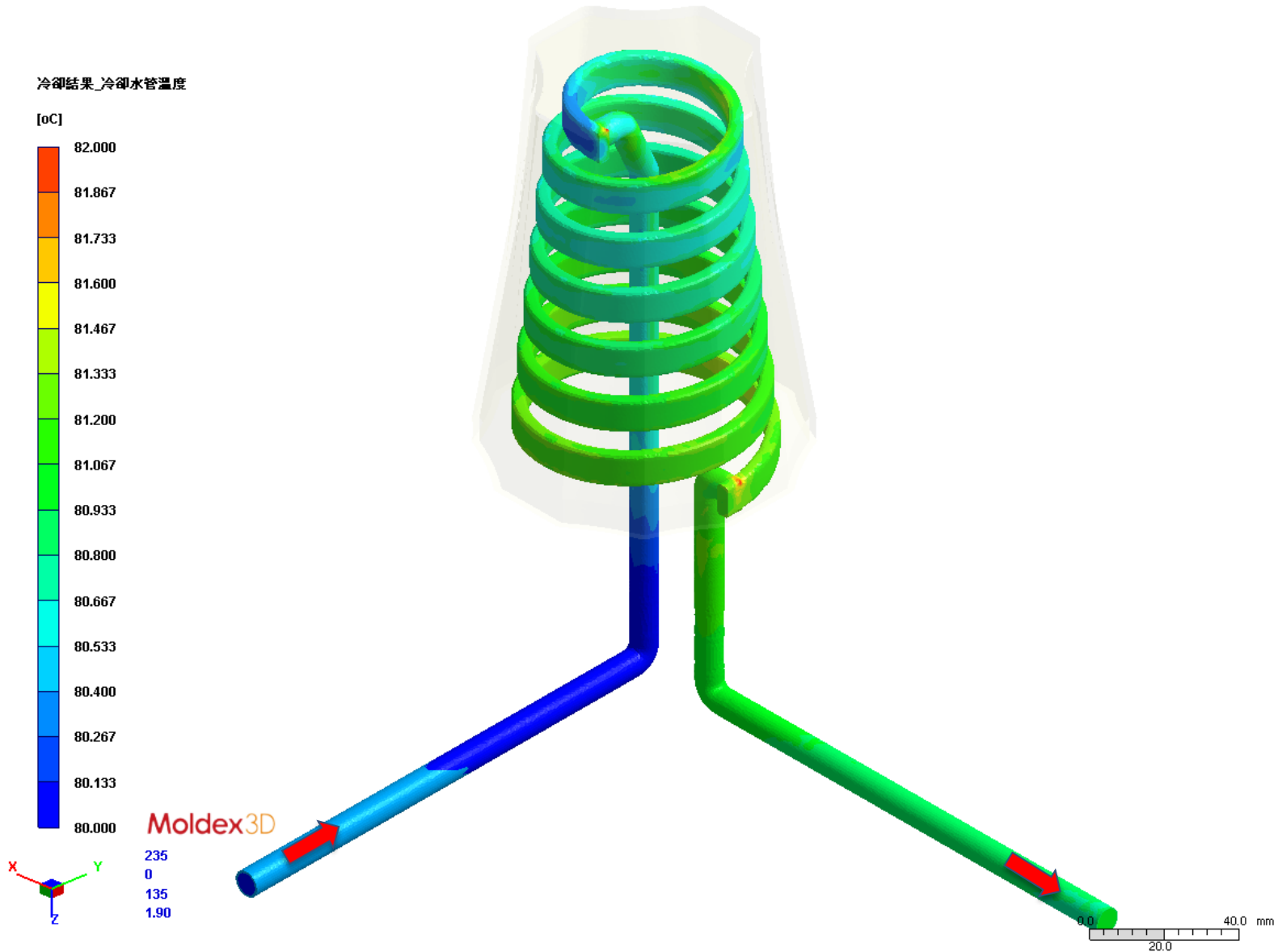

冷卻水路壓力分布

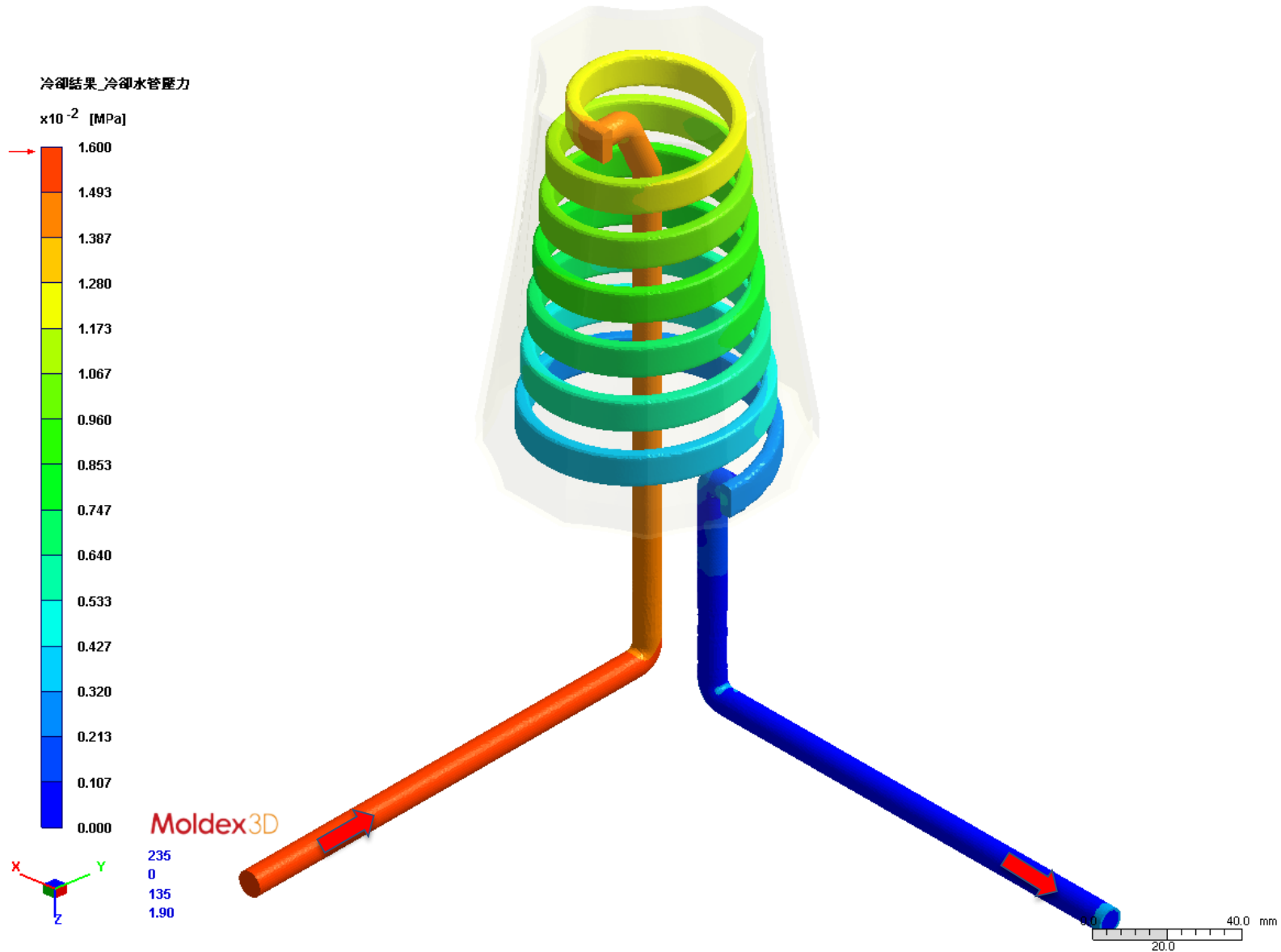

冷卻水路速度場流線分布

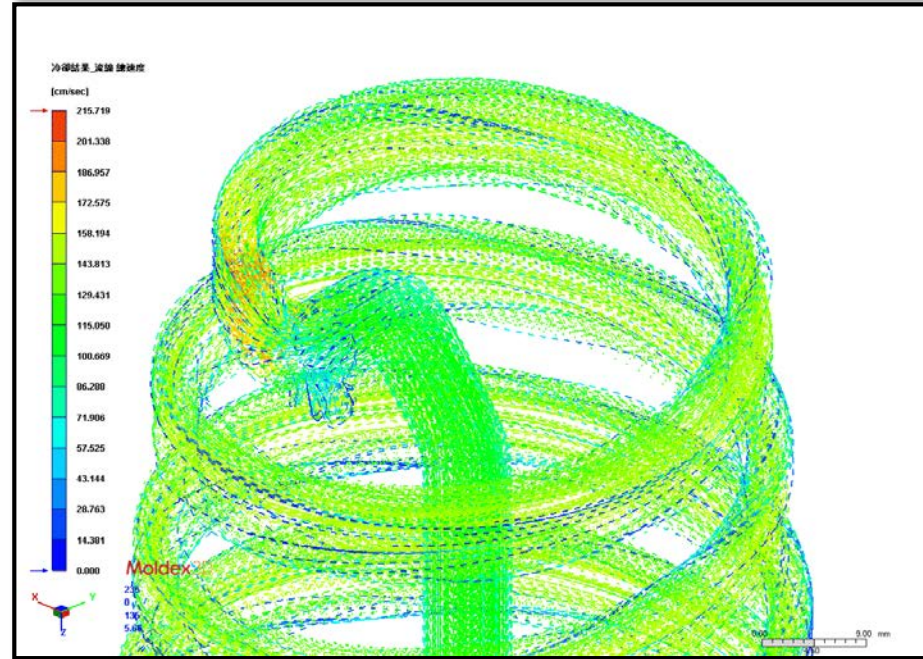
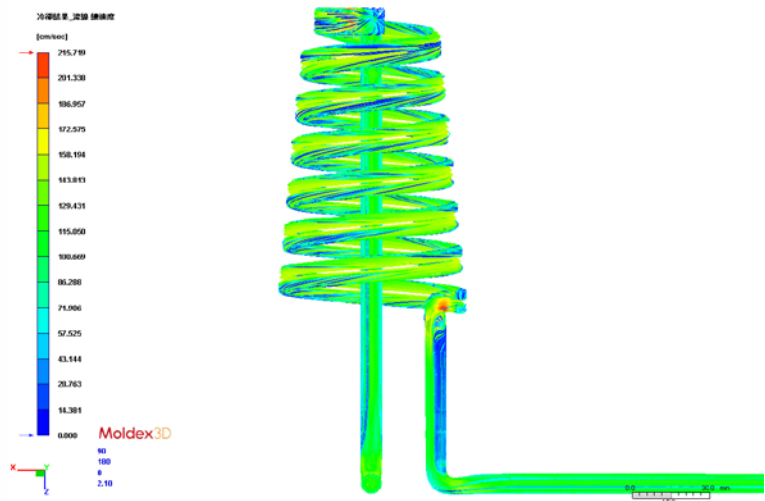
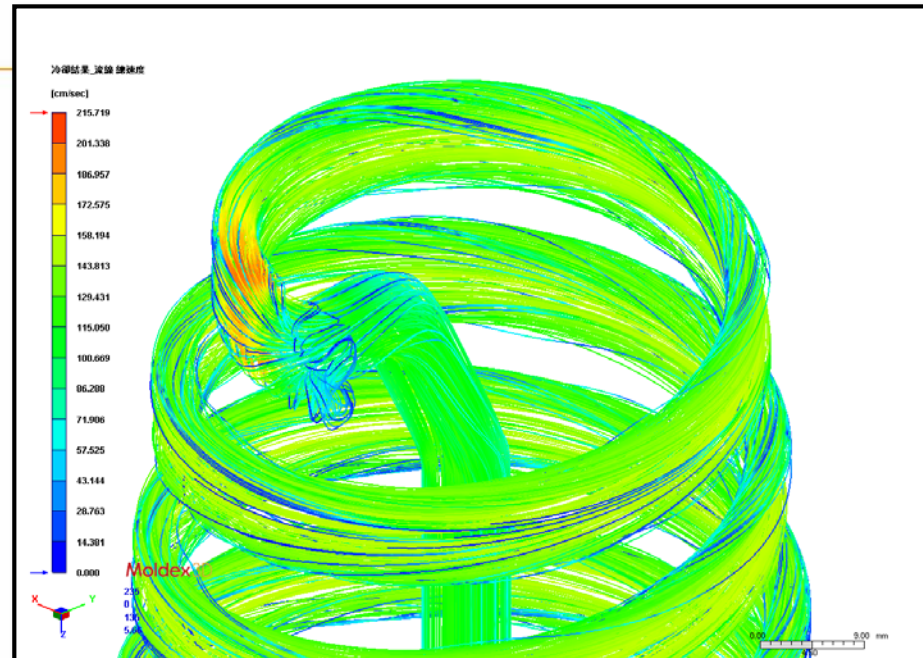
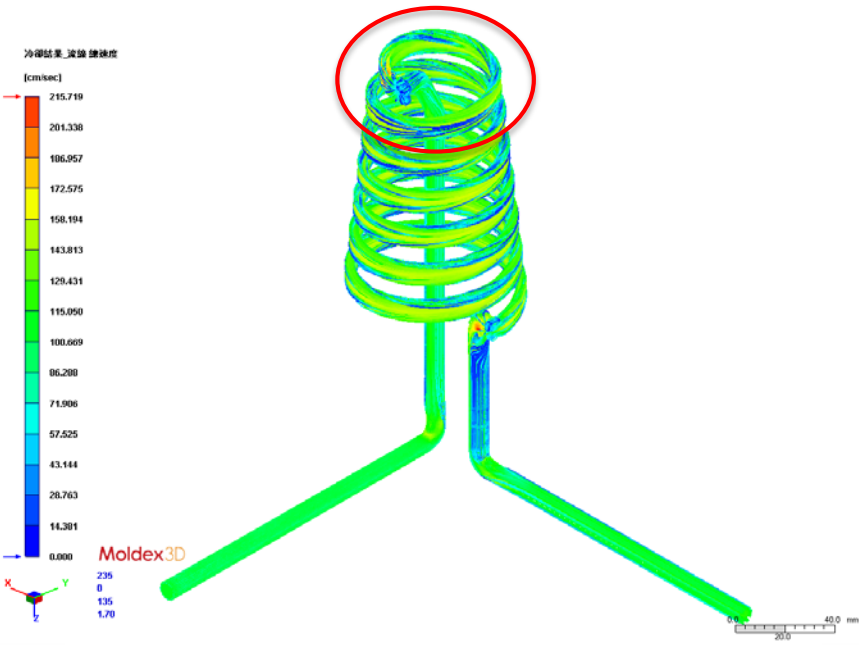

模具表面溫度歷程曲線

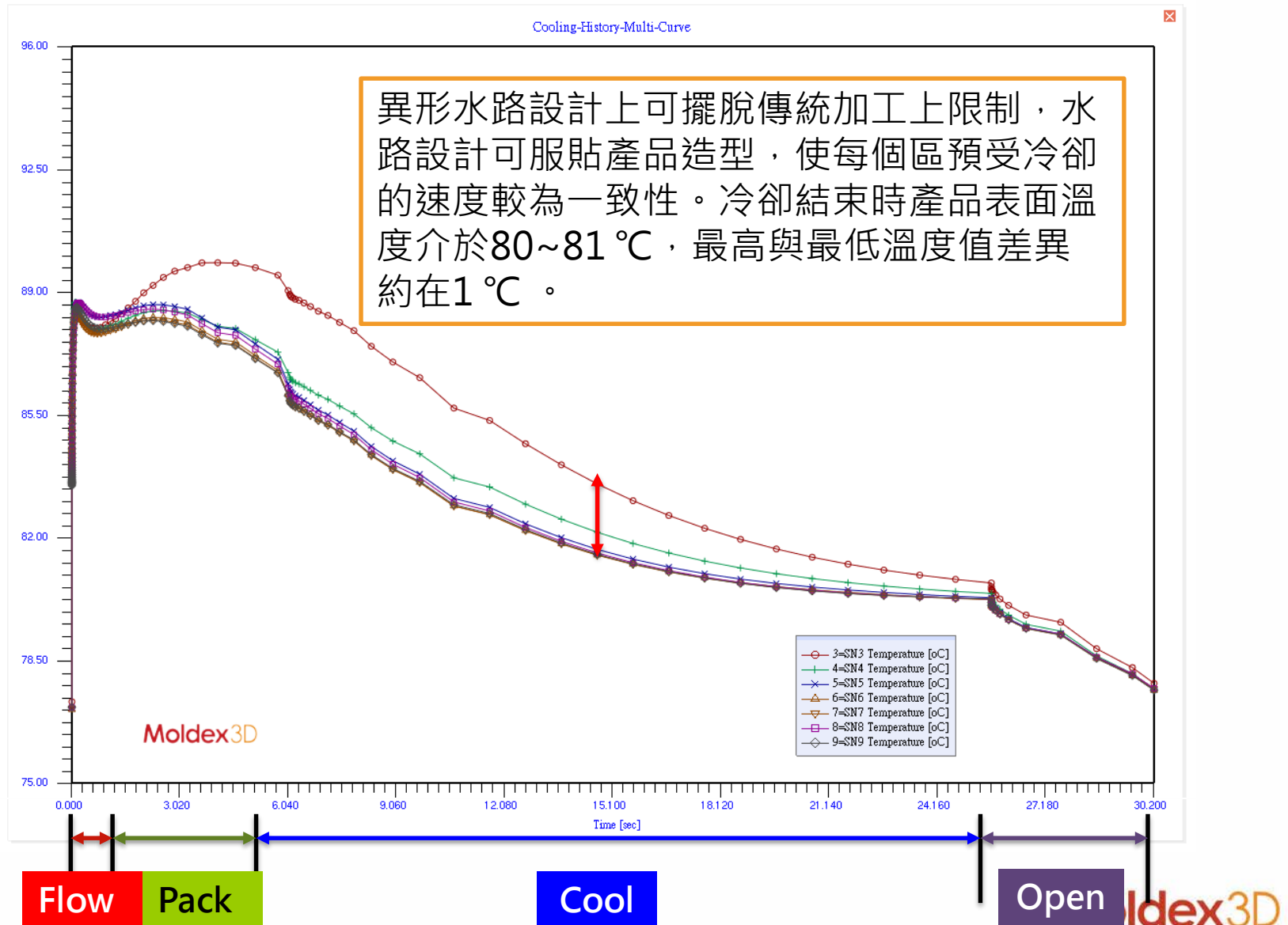

Conformal Cooling Example

Moldex3D

产品结构_剖视图

Part 1: PC(SABIC) (LEKAN 840A)
Hot Runner: PC(SABIC) (LEKAN 940A)

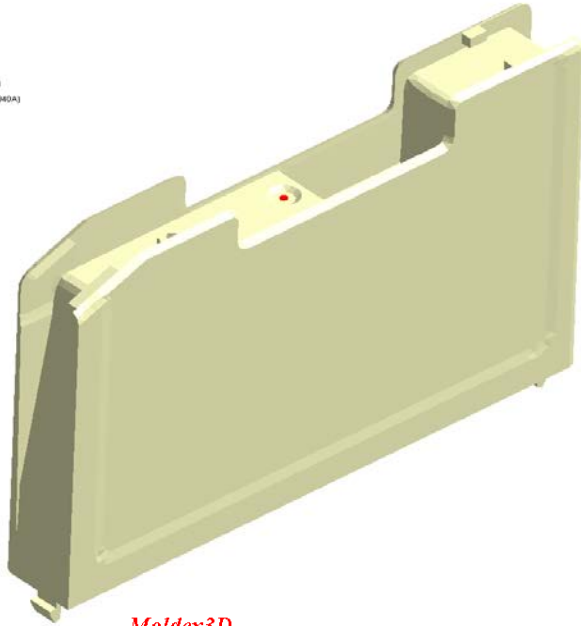

Moldex3D

Warpage_Z-Displacement

$\times 10^{-1}$ [mm]

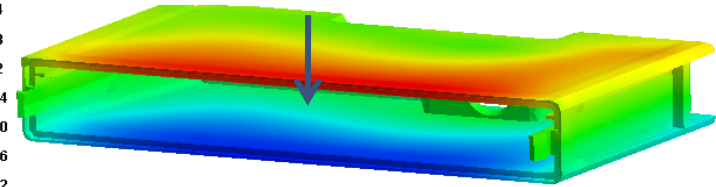
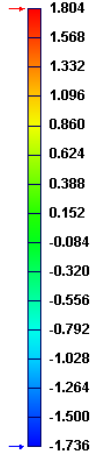

259
359
153
1.80

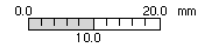

Moldex3D

Cooling_Temperature

$\times 10^0$ [°C]

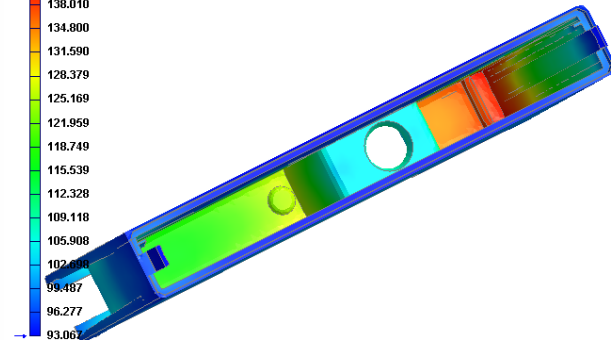
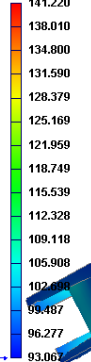

271
333
199
2.00

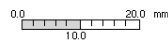

Moldex3D

Mould Cooling Temperature

Mould temperature rising in core

Local temperature rise to 140oC

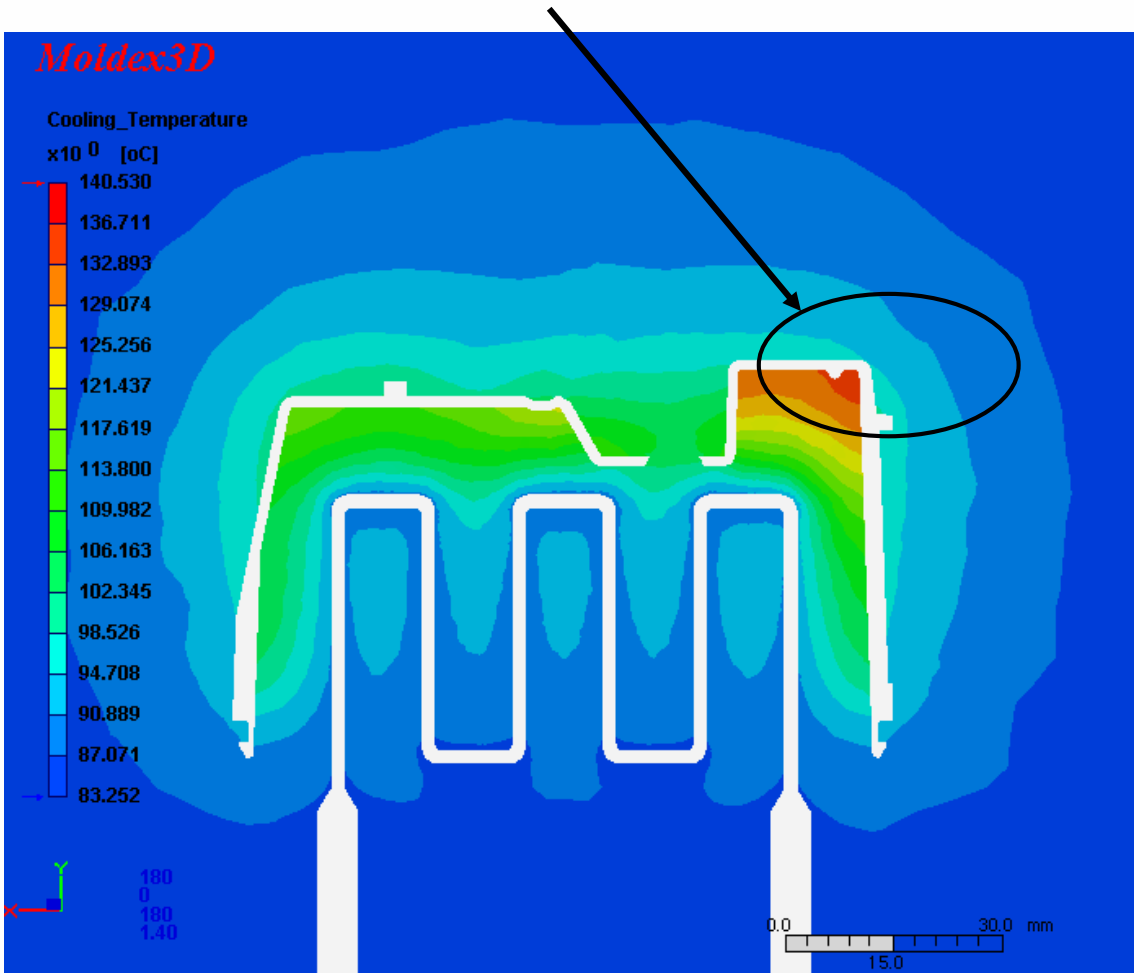

Moldex3D

Model_Shaded Model

Coolant-1:Water

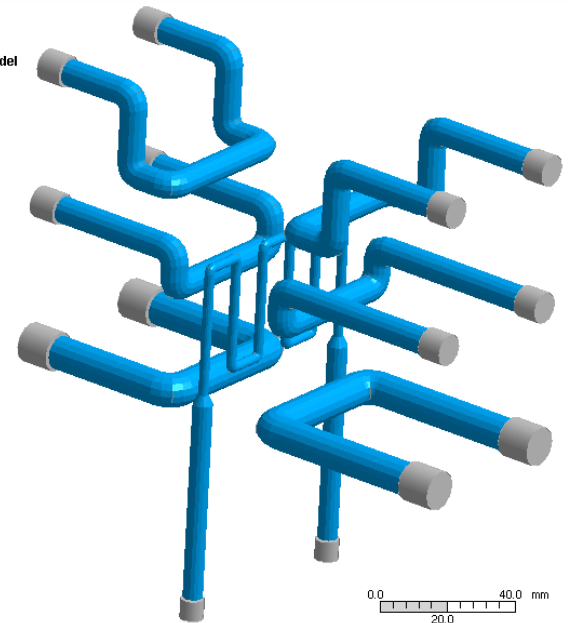

Mold temperature – 90oC

Moldex3D

Conformal Cooling Example

Conformal cooling (順形冷卻) is defined as the ability to create cooling / heating configurations within a tool that essentially follows the contour of the tool surface or deviates from that contour as thin / thick sections of the part may dictate for optimal thermal management.

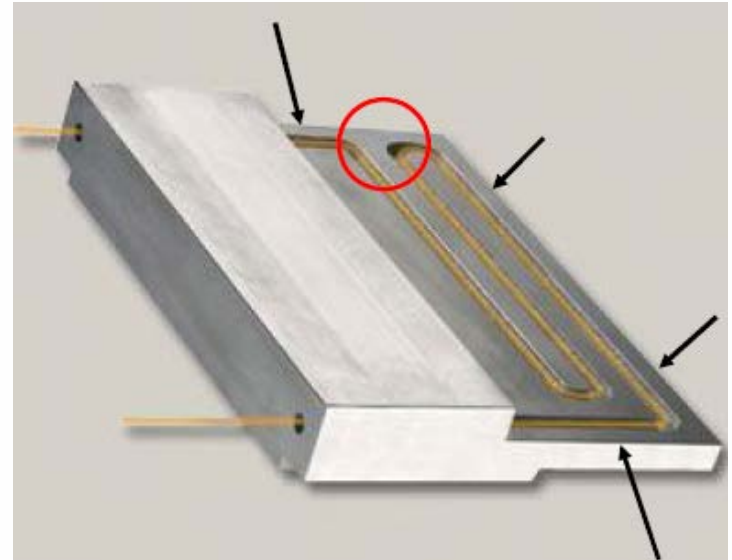

Mould Cooling Temperature

Improved performance verified using Moldex3D

Local temperature drop to 105oC

Moldex3D

Cooling_Temperature

$\times 10^0$ [oC]

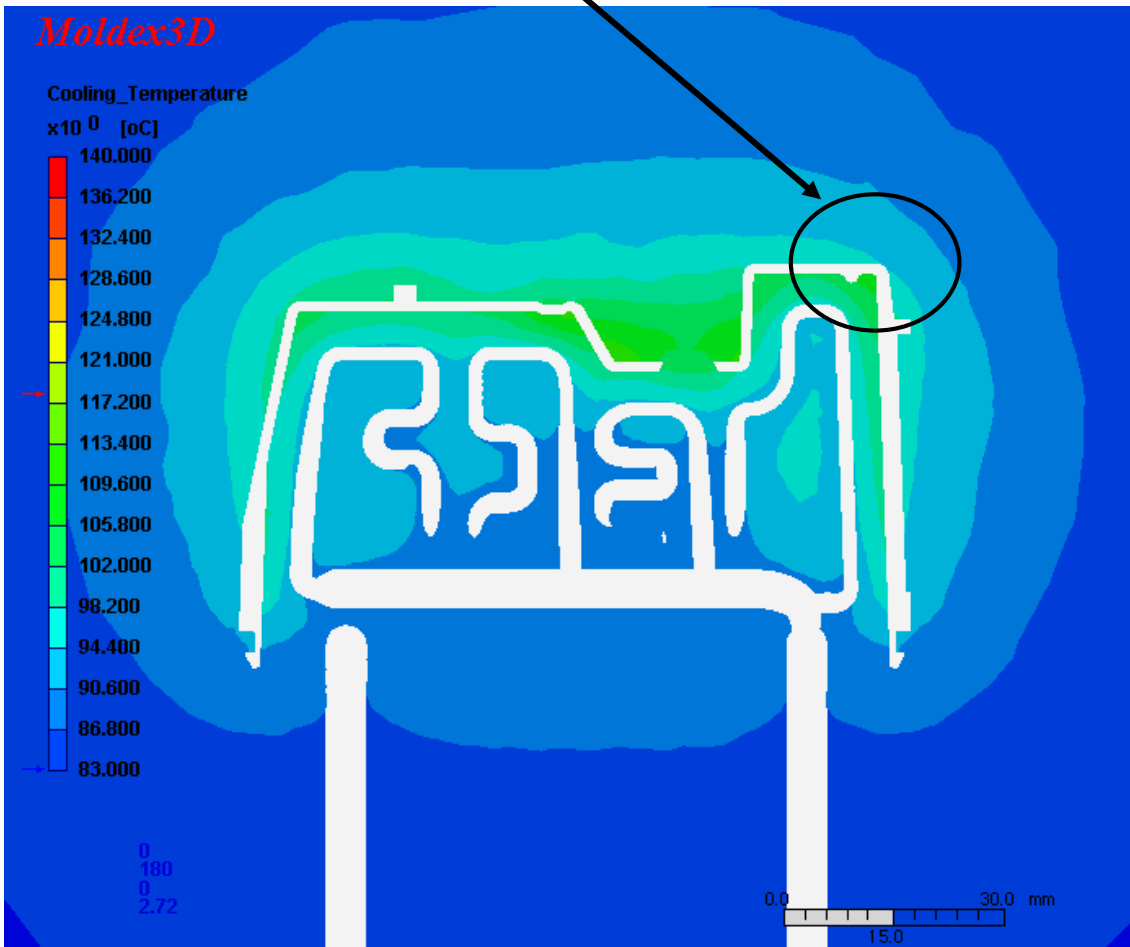
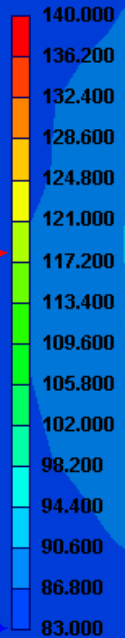

Moldex3D

Model_Shaded Model

Coolant: Undefined
Coolant-1: Water

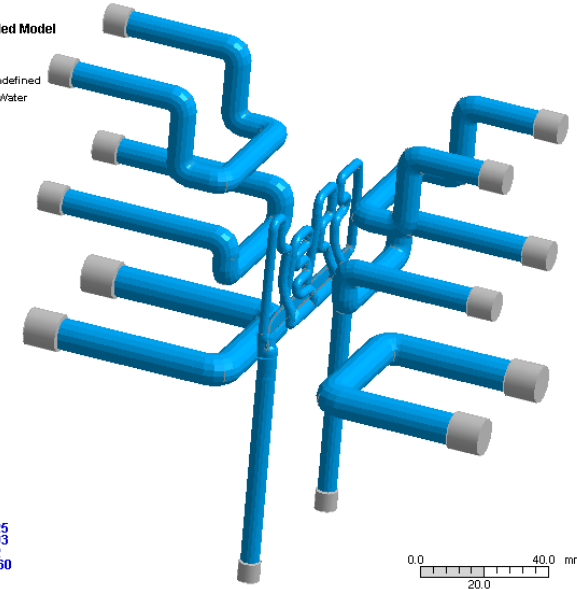

Moldex3D

Model_Shaded Model

Part-1 (PC) SBRIC (DE) LERAN 300A
Part-2 (PC) SBRIC (DE) LERAN 300A
Moulding-1 (polyamide) 1077
Mould-Cooling Unit
Coolant: Undefined
Coolant-1: Water

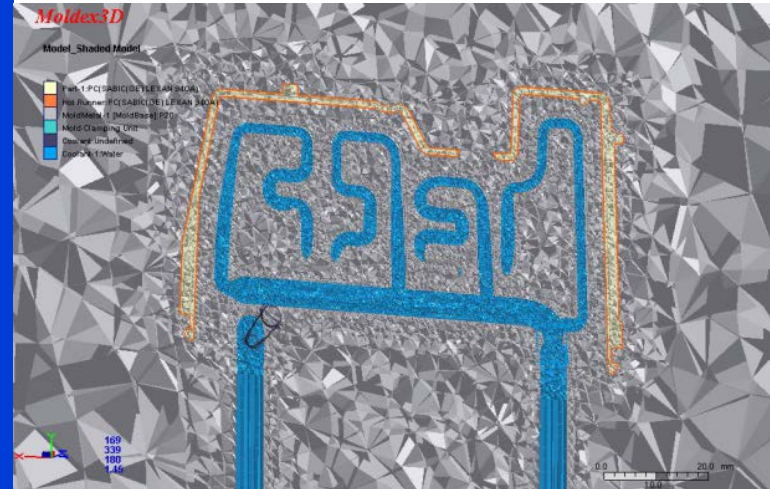

Moldex3D

Part Surface Temperature

Temperature difference across wall thickness reduced 85% from 40oC to 6oC

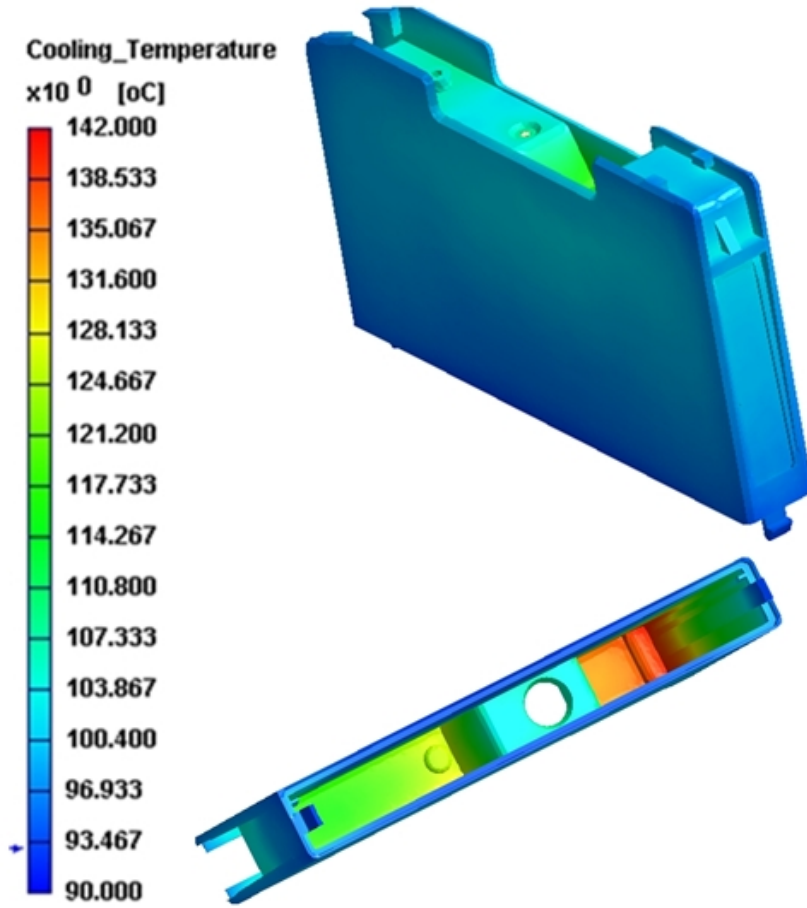

Conventional Cooling

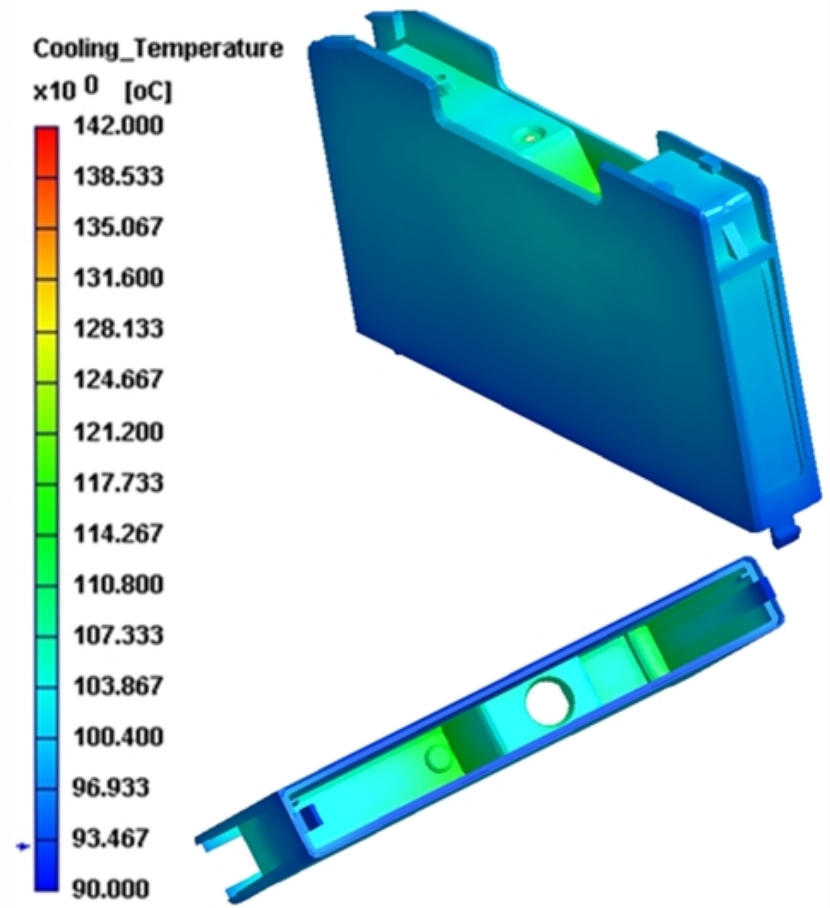

Conformal Cooling

Conventional
Cooling

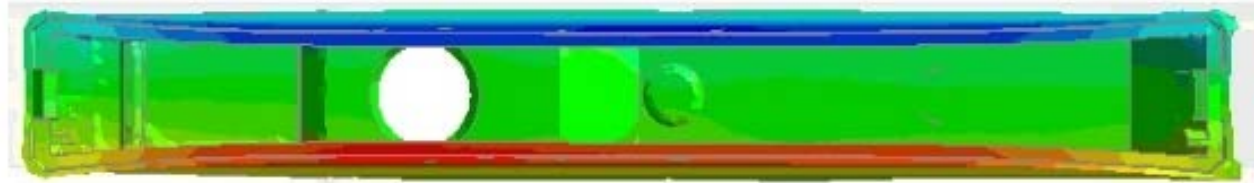

Conformal
Cooling



Warpage is reduced by 26%

測試案例I (傳統注口襯套無水路設計)

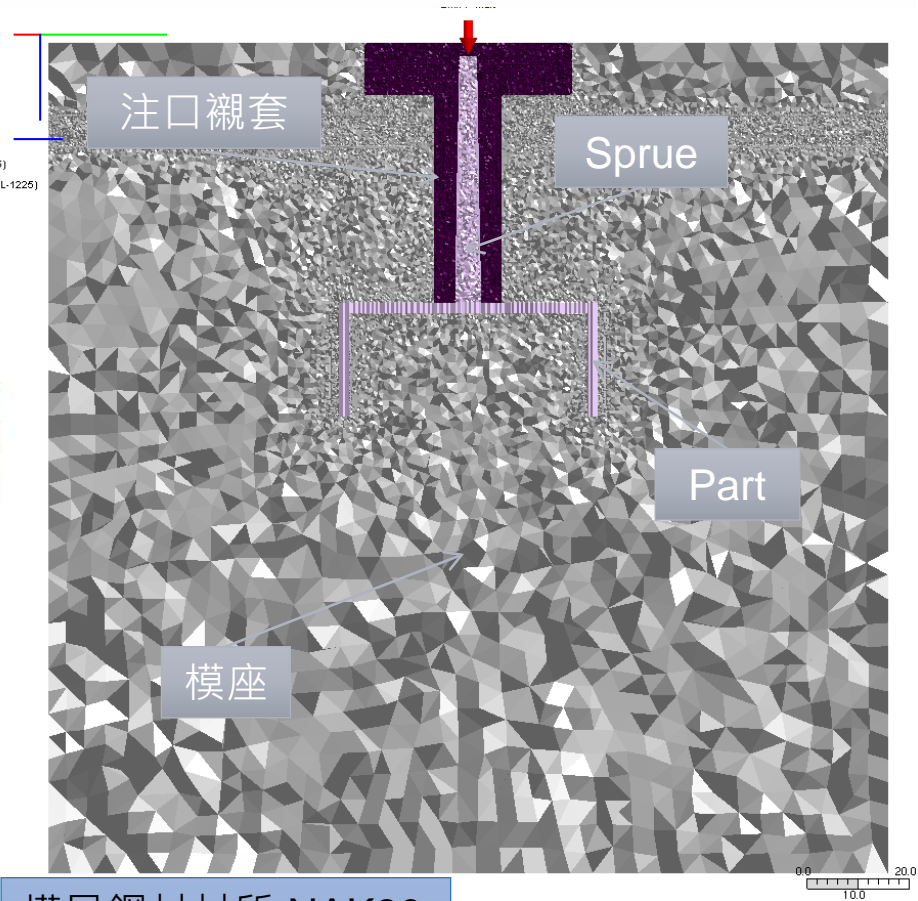
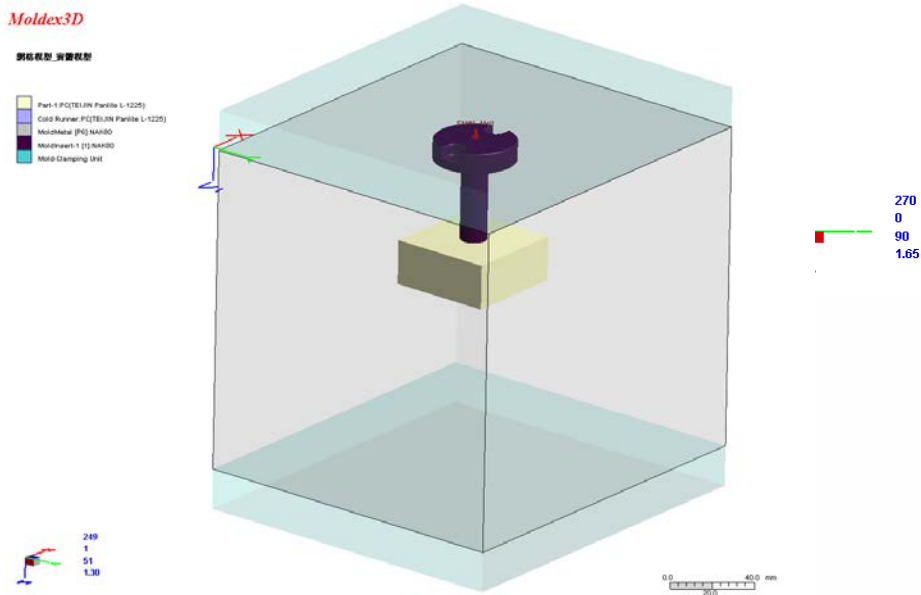
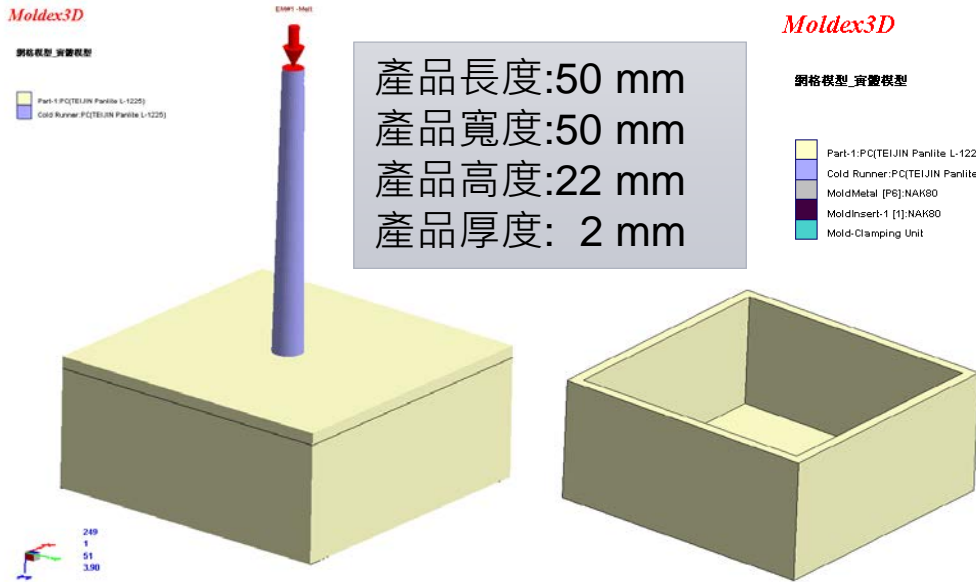

模具鋼材材質: NAK80
產品材料: PC
材料頂出溫度: 135°C
模具溫度: 100°C
冷卻時間: 15s

傳統設計組別

Moldex3D

測試案例I (傳統注口襯套無水路設計)

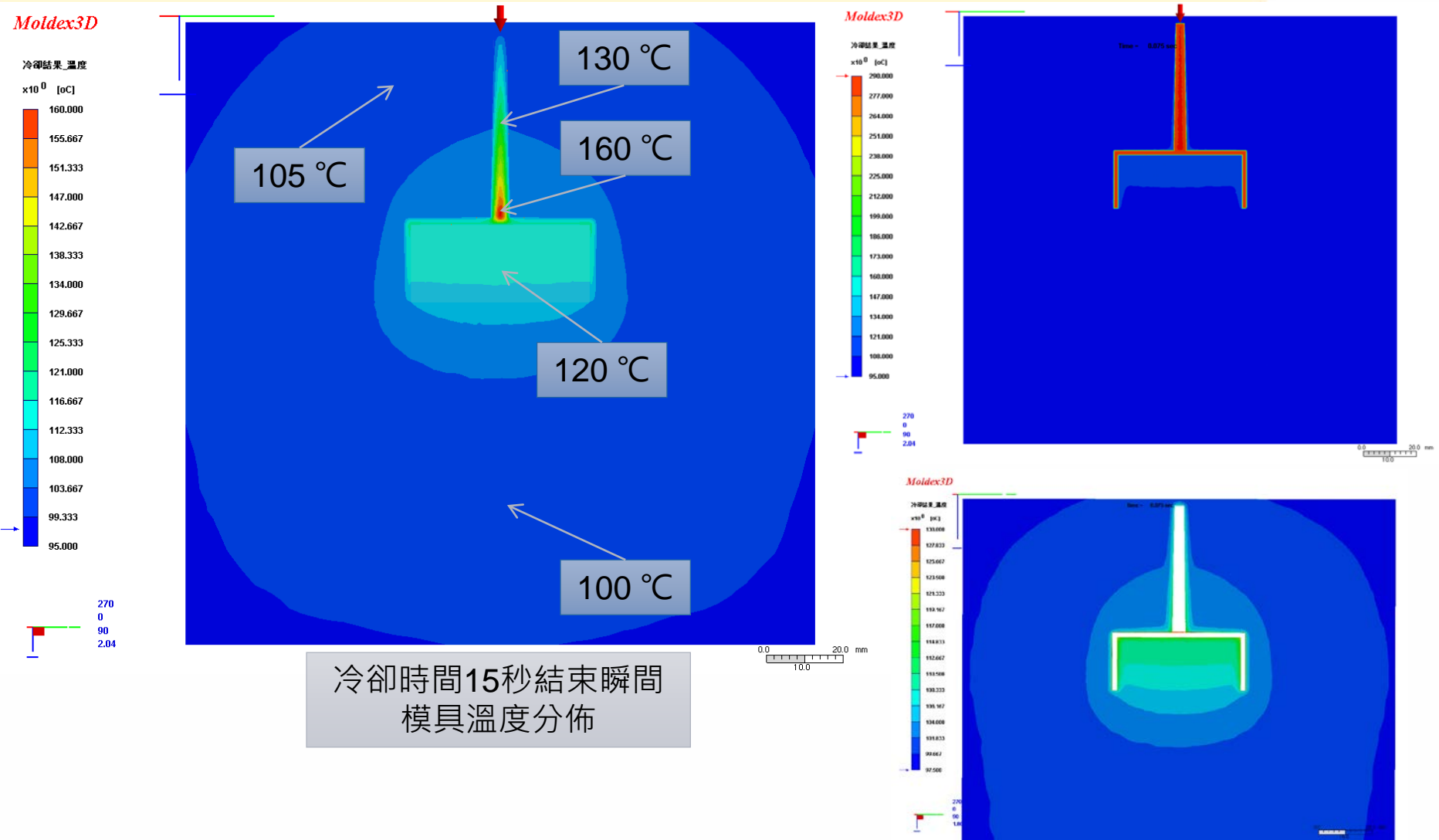

冷卻時間15秒結束瞬間
模具溫度分佈

成型週期間模具溫度分佈

模具溫度分佈範圍:95~160 °C

測試案例I (注口襯套異型水路設計)

Moldex3D

網格模型_實體模型

- Part-1:PC[TEIJIN Parilite L-1225]
- Cold Runner:PC[TEIJIN Parilite L-1225]
- Coolant-1:Water

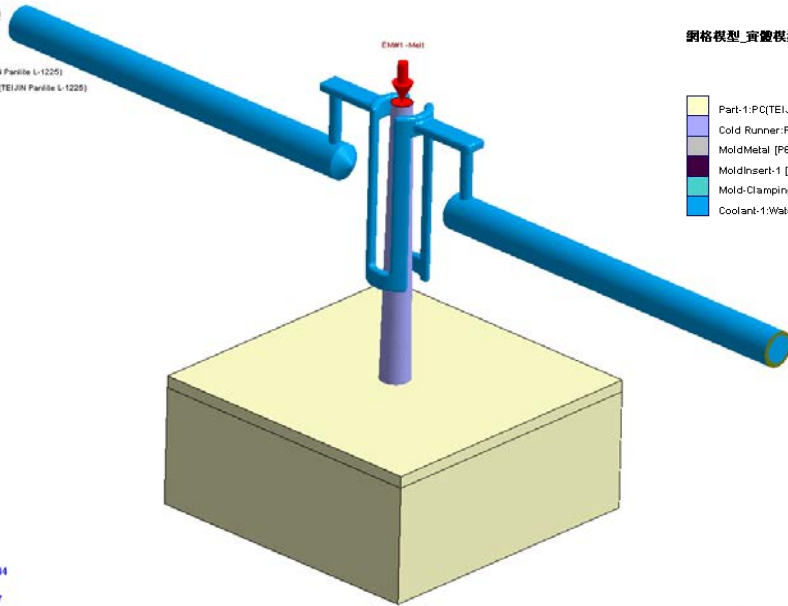

Moldex3D

網格模型_實體模型

- Part-1:PC[TEIJIN Parilite L-1225]
- Cold Runner:PC[TEIJIN Parilite L-1225]
- MoldMetal [P6]:NAK80
- MoldInsert-1 [1]:NAK80
- Mold-Clamping Unit
- Coolant-1:Water

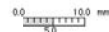

270
0
90
1.81

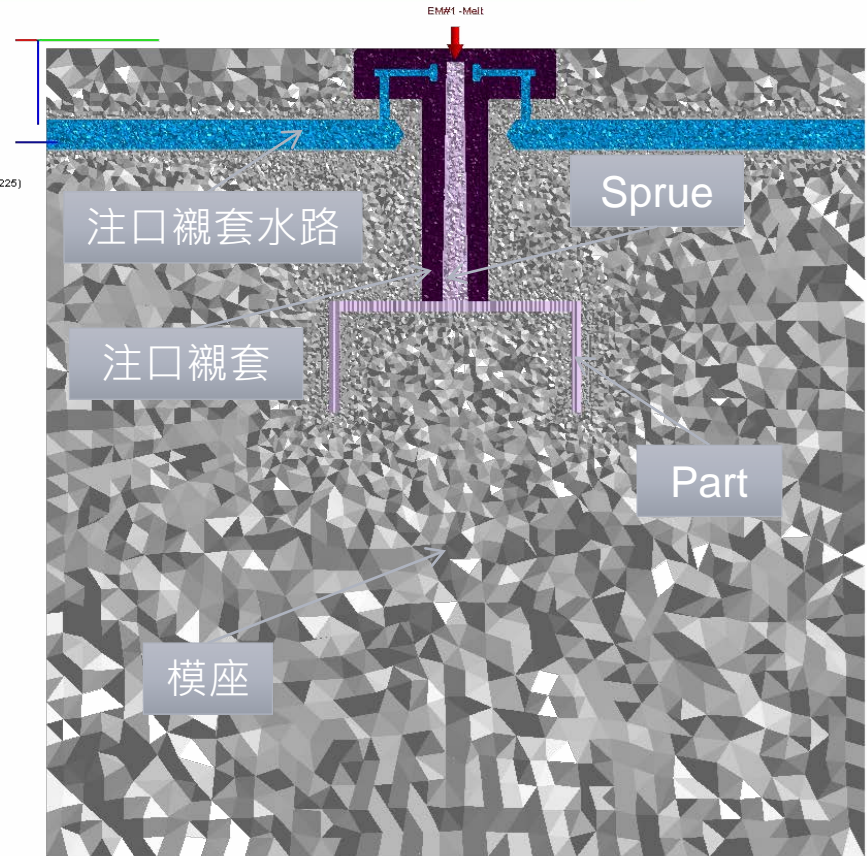

244
1
47
0.93

Moldex3D

網格模型_實體模型

- Part-1:PC[TEIJIN Parilite L-1225]
- Cold Runner:PC[TEIJIN Parilite L-1225]
- MoldMetal [P6]:NAK80
- MoldInsert-1 [1]:NAK80
- Mold-Clamping Unit
- Coolant-1:Water

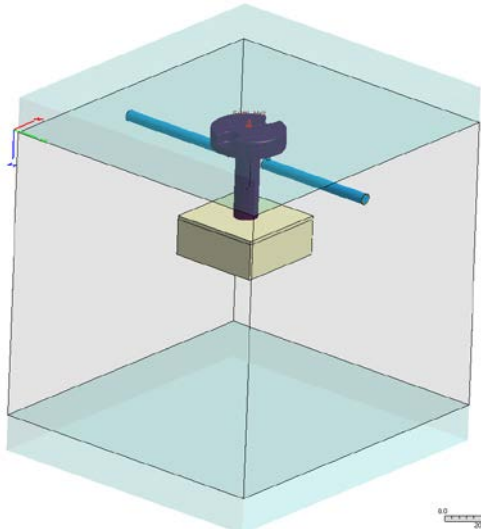

模具鋼材材質:NAK80
 產品材料:PC
 材料頂出溫度:135°C
 模具溫度:100°C
 襯套水路溫度:80 °C
 冷卻時間:15s

異型水路設計組別

Moldex3D

測試案例I (注口襯套異型水路設計)

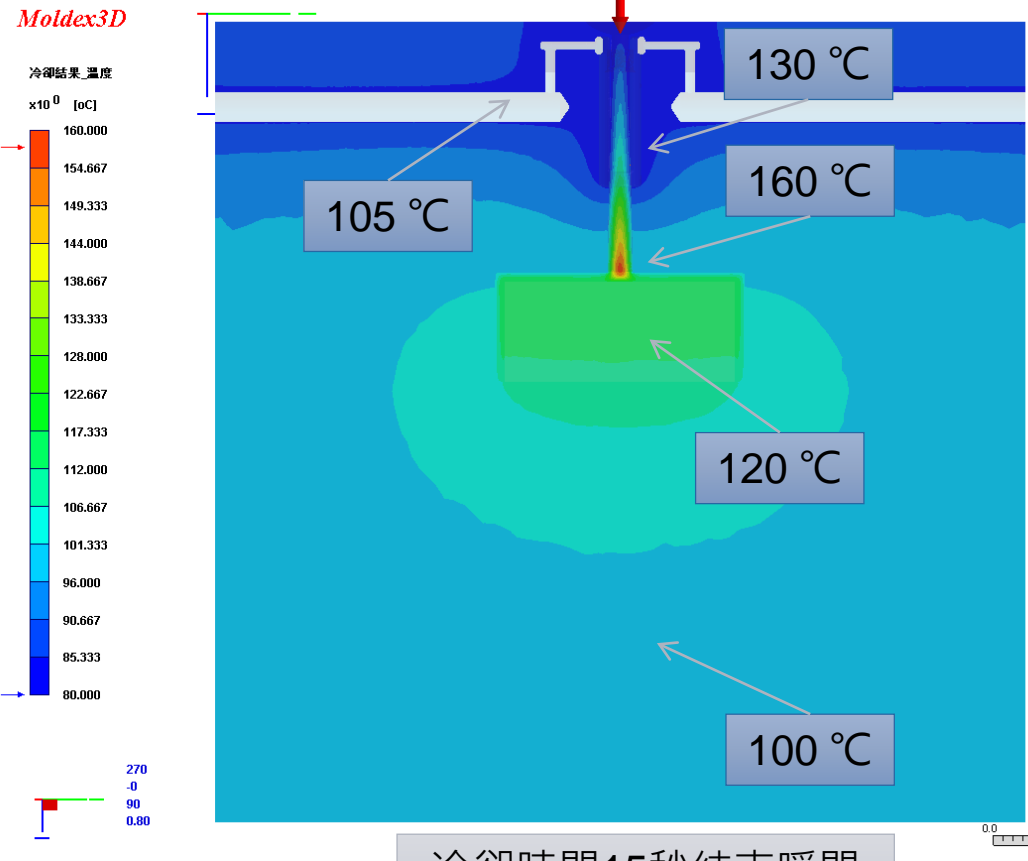

冷卻時間15秒結束瞬間
模具溫度分佈

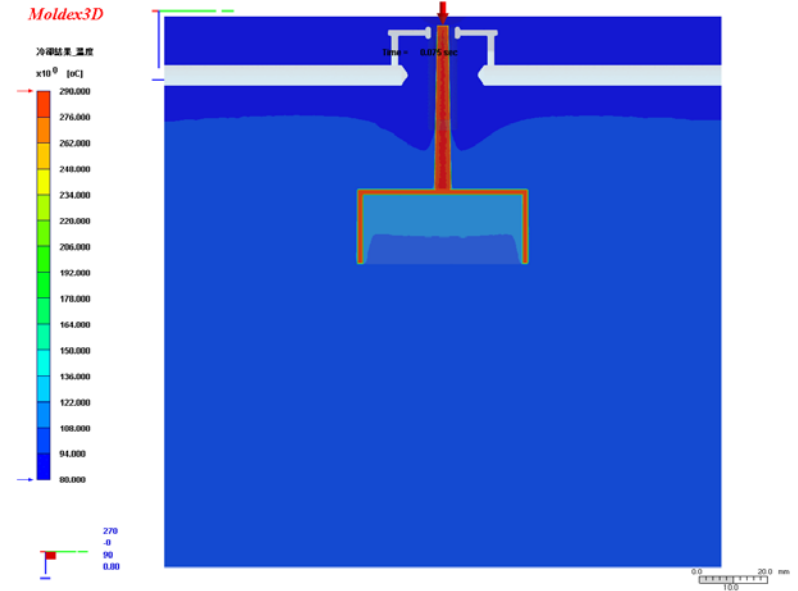

成型週期間模具溫度分佈

模具溫度分佈範圍:80~160 °C

測試案例I (組別資料比較)

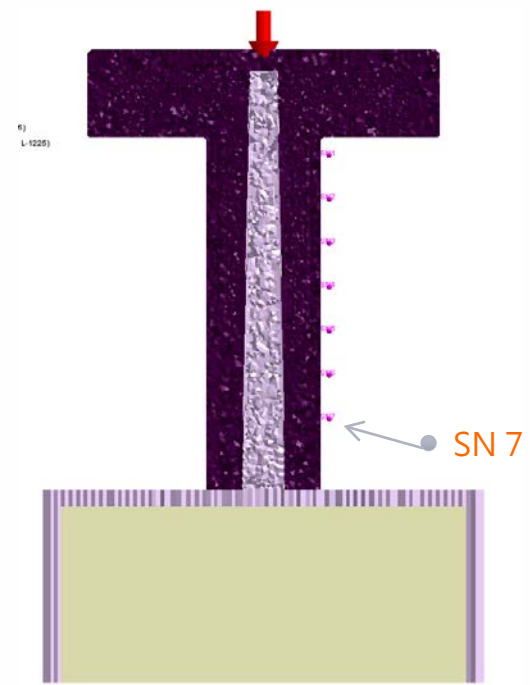
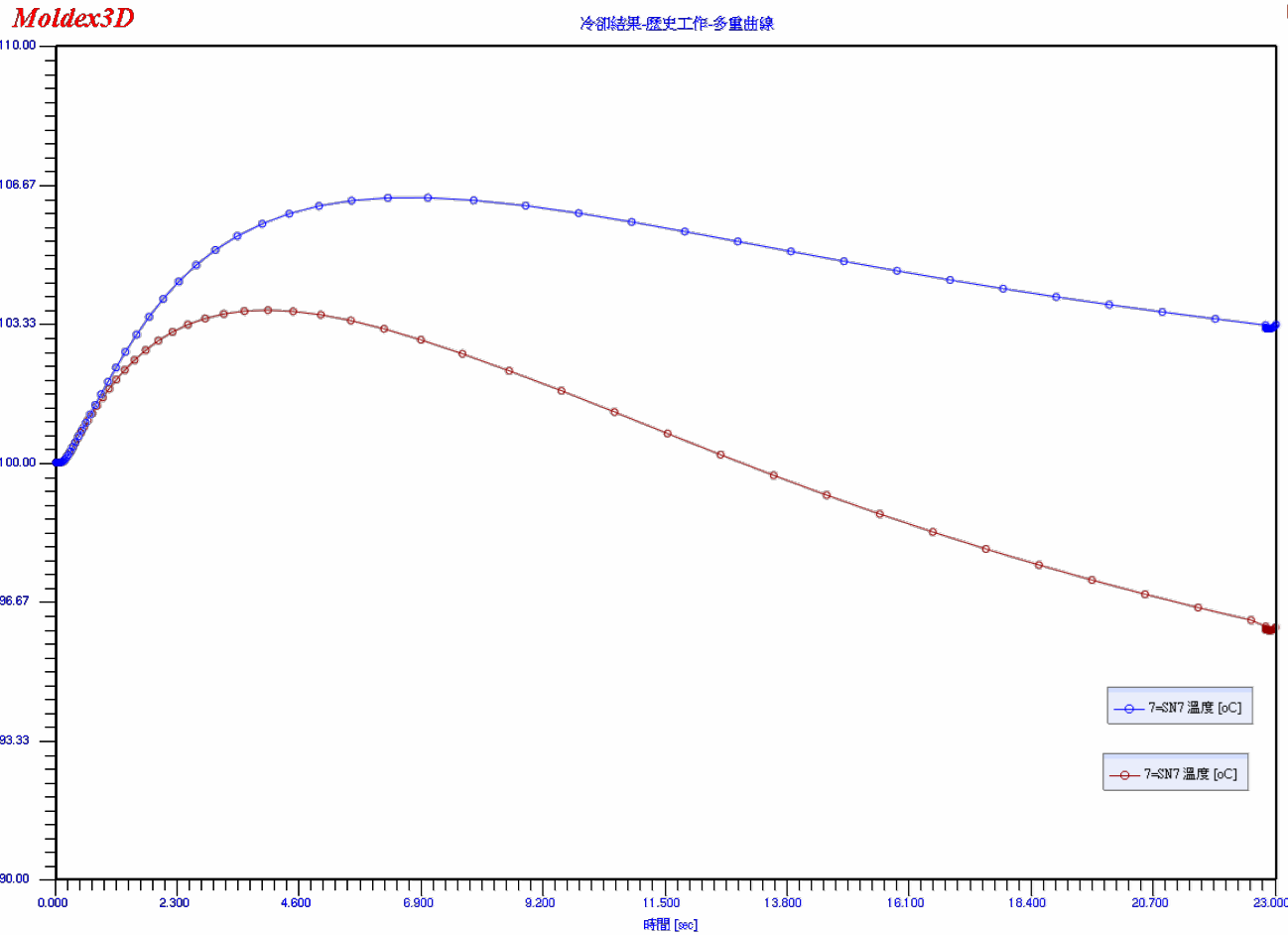

- 注口襯套無水路設計
- 注口襯套異型水路設計

雖然注口襯套靠近澆口外緣處沒有異型水路環繞，但此部分的熱量仍能透過上方襯套內水路傳遞，因此SN7位置上，模具溫度傳遞速率仍較傳統式襯套迅速，減少料頭冷卻時間，進而使成型週期縮短。

鋼板成型_資費模型

- Part 1-PC(SABIC(QE))(LEXAN 141)
- Cold Runner-PC(SABIC(QE))(LEXAN 141)
- MoldSteel-2(Mextral)P6
- MoldSteel-1 (MevMetal)P6
- Mold-Clamping Unit
- Coolant-1-Water

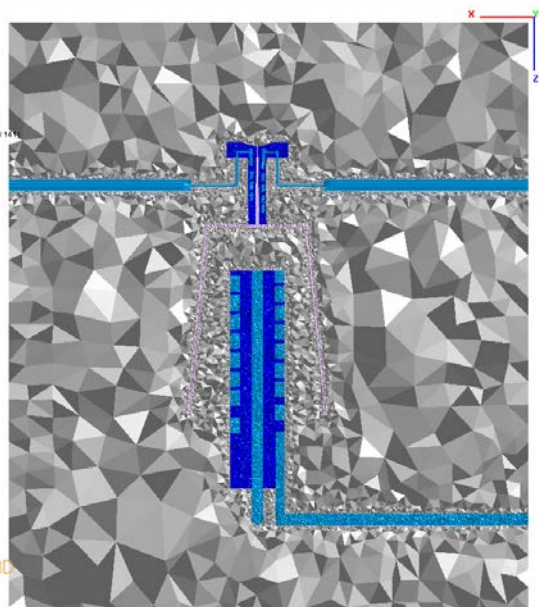

Moldex3D
90
100

鋼板成型_資費模型

- Part 1-PC(SABIC(QE))(LEXAN 141)
- Time-Action-PC(SABIC(QE))(LEXAN 141)
- MoldSteel-2(Mextral)P6
- MoldSteel-1 (MevMetal)P6
- Mold-Clamping Unit
- Coolant-1-Water

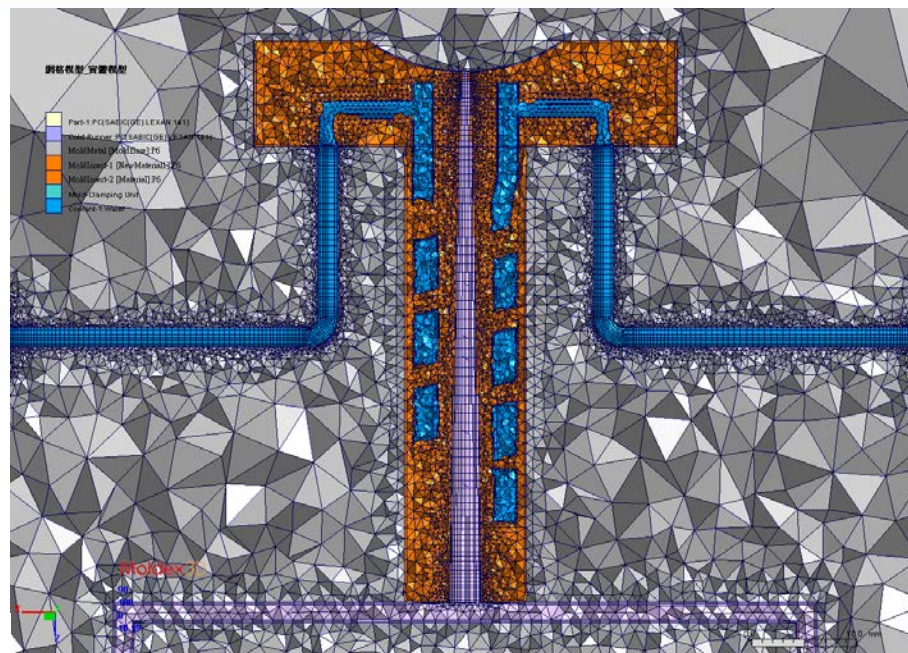

Moldex3D
90
100

鋼板成型_資費模型

- Cold Runner-PC(SABIC(QE))(LEXAN 141)
- MoldSteel-2(Mextral)P6
- Coolant-1-Water

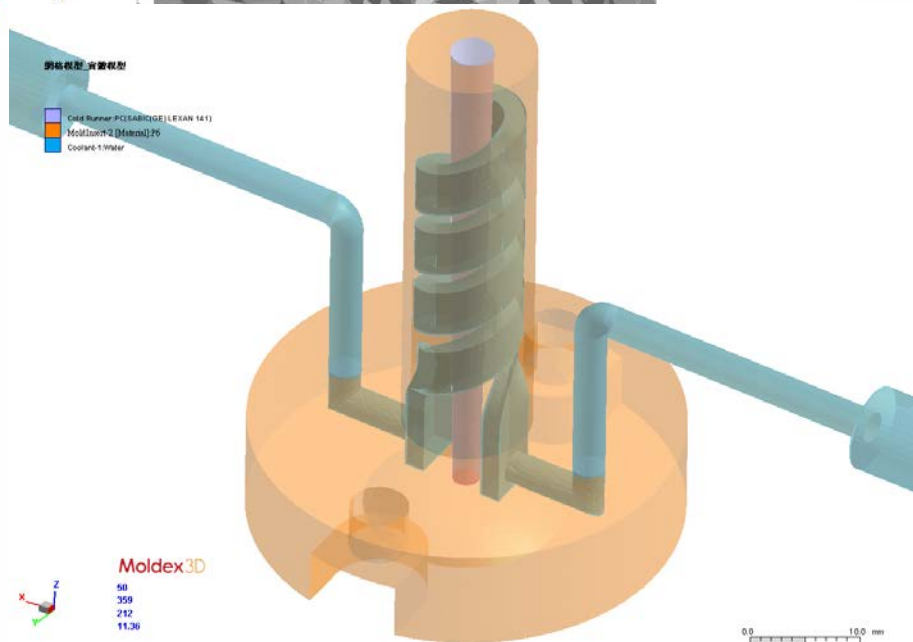

Moldex3D
50
359
232
11.26

00 50 100 mm

鋼板成型_資費模型

- Part 1-PC(SABIC(QE))(LEXAN 141)
- Cold Runner-PC(SABIC(QE))(LEXAN 141)
- Coolant-1-Water

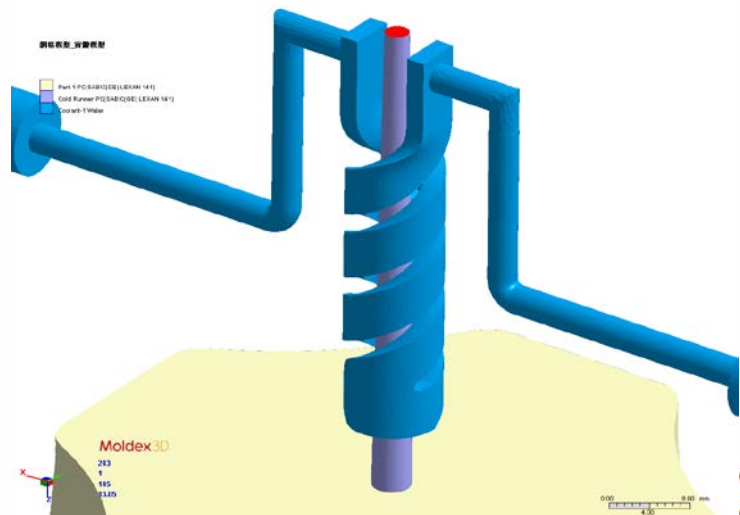

Moldex3D
293
1
145
7310

000 800 mm
430

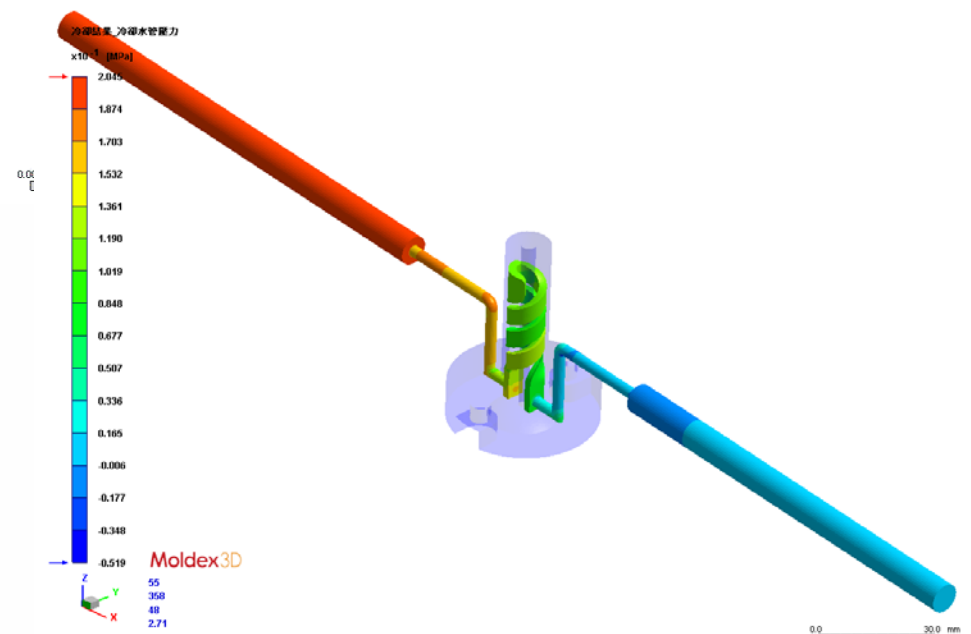
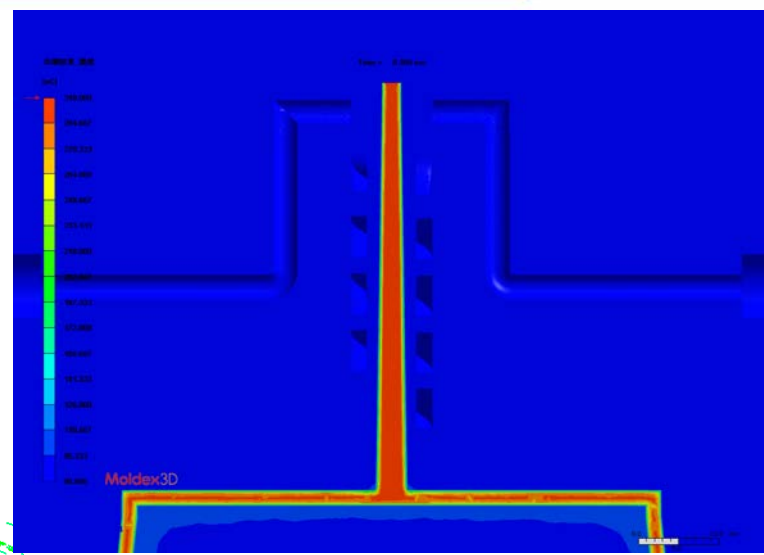
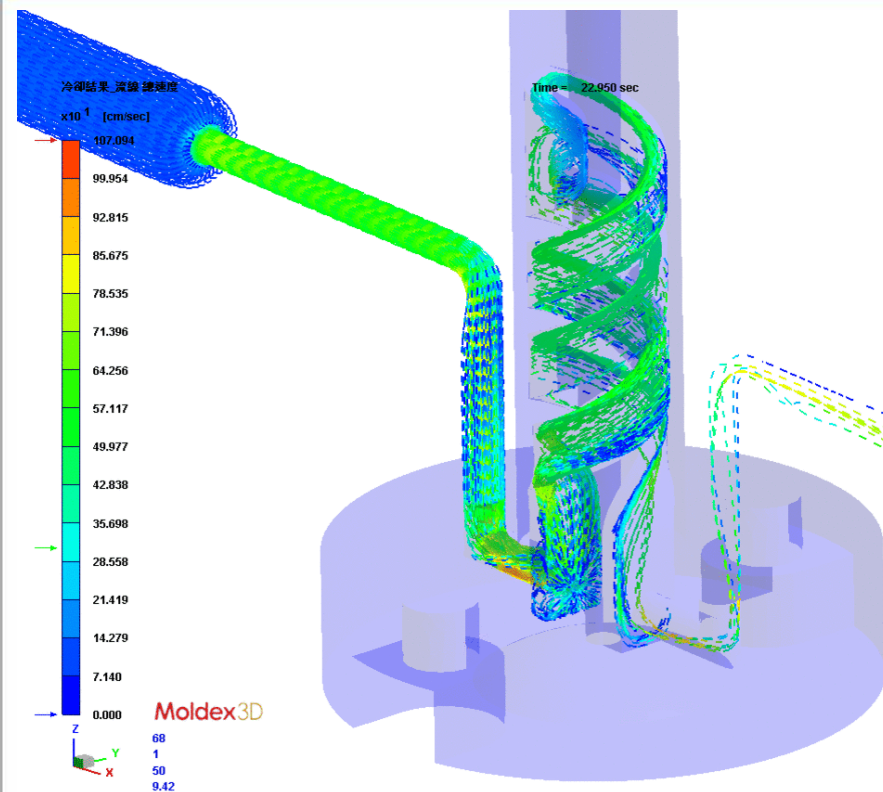



Moldex3D

MOLDING INNOVATION

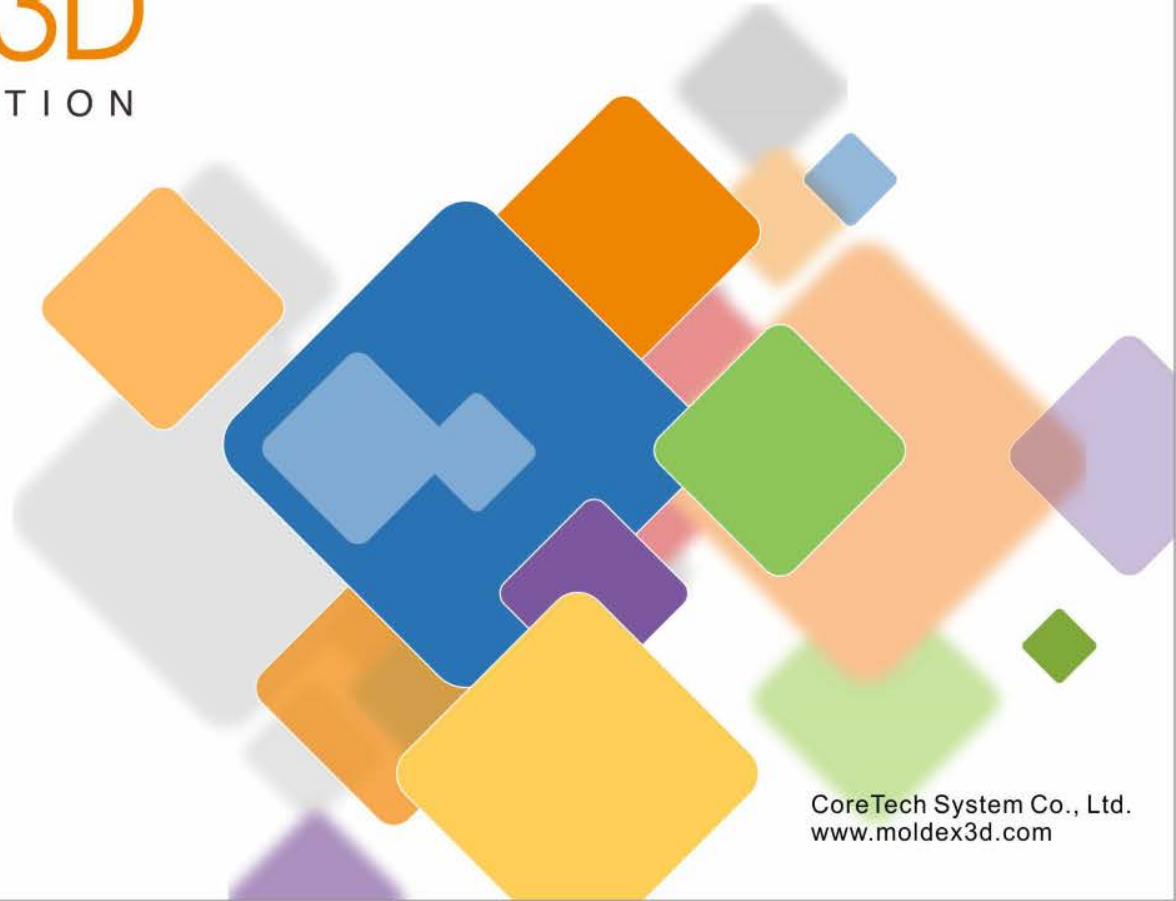

CoreTech System Co., Ltd.
www.moldex3d.com