

BUSINESS MEETINGS

One to one business meetings between buyers and suppliers from the whole value chain of composites

CONFERENCES

Workshops from suppliers and conferences

INNOVATION

Explore innovative technologies and projects shaping the industry's future



JEC FORUM SOUTHEAST ASIA 2026

Business Meetings & Conferences

June 23-24, 2026 | TAIPEI
TAIWAN

In partnership
with

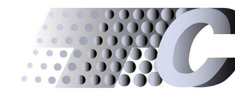

NETWORKING

Networking opportunities during the coffee and lunch breaks and the Evening Networking Reception

COMPOSITES TOUR

A one-day company visit to discover the composites industry of the Region

◆ ◆ ◆ **BUSINESS MEETINGS**
EVENT for the composites industry in Southeast Asia

www.jec-southeast-asia.events



PARTICIPATION PACKAGE

◆ ◆ ◆ **BUSINESS MEETINGS**

EVENT for the composites industry in Southeast Asia

ABOUT THE ORGANISERS



The JEC Forum Southeast Asia is an event organized by JEC

The inaugural JEC Forum Southeast Asia was held on June 11 and 12, 2024, in partnership with the Thai Composites Association (TCA), bringing together the composite materials community in Southeast Asia.

Building on this success, the second edition is scheduled for June 23 and 24, 2026, in Taipei, Taiwan. This upcoming forum is organized by JEC in collaboration with the Taiwan Composites Association and SAMPE Taiwan, aiming to further unite and strengthen the composites industry in the region.

About JEC: JEC is a global organization dedicated to promoting composite materials. It offers a range of resources, including knowledge sharing, networking opportunities, and innovation programs, to connect professionals and advance the composites industry worldwide.

jeccomposites.com

A PARTNERSHIP BASED ON KNOWLEDGE



About Taiwan Composites Association

About Taiwan Composites Association:

Established in 1976, the Taiwan Composites Association (formerly known as the Society of RP/C, R.O.C.) is the largest and most active composite society in Taiwan. With over 200 company members and 30 individual members, the association provides technical services, coordinates industry efforts, promotes new technologies, and organizes conferences and seminars to advance the composite materials sector in Taiwan.

<http://www.sampe-taiwan.org.tw>

The upcoming JEC Forum Southeast Asia in Taipei promises to be a pivotal event, fostering collaboration and innovation within the composites community across the region.

JEC FORUM SOUTHEAST ASIA 2026

Business
Meetings &
Conferences

June 23-24, 2026 | TAIPEI
TAIWAN

SUPPORTING PARTNERS

THANK YOU



TCLcCA

Taiwan Composite Low-Carbon Circular Alliance

臺灣複材低碳

循環聯盟

WHY TAIPEI TAIWAN



The gateway between Asia and the global composites industry

Taiwan plays a central role in the composites supply chain, bridging Asian, American, and European markets.

The transition gateway between Mainland China, North Asia and Southeast Asia.

Our target audience spans the entire value chain of the composites industry, drawing participants from **Brunei, Cambodia, India, Indonesia, Laos, Malaysia, Mainland China, Myanmar (Burma), the Philippines, Singapore, Taiwan, Thailand, East Timor, South Korea, Japan, and Vietnam.**

THE FORUM WILL BE HELD IN THE GRAND HILAI TAIPEI



A premium setting for an unforgettable event. The JEC Forum Southeast Asia 2026 will take place in a carefully selected 5-star hotel, combining prestige, comfort, and excellence to foster strategic business meetings.

JEC FORUM SOUTHEAST ASIA IN FIGURES



Business Meetings



High Value Conferences



Innovation session



Composites Tour



Evening Networking Event



100

buyers



250

participants



20

speakers



450

business meetings



2+1

2 days Business meetings and 1 day Composites Tour



50

supplying companies

2026 expected figures for the second edition

THREE PILLARS

The event focuses on
three pillars

1 BUSINESS MEETINGS

The Business Meetings program is a strategic driver for connections and business growth across the entire composites value chain. By combining targeted matchmaking with a digital platform, it enables participants to build high-value partnerships before and during the event.

2 CONFERENCES

The program features a dynamic mix of keynotes, panel discussions, supplier-led workshops, and an Innovation Startups session, covering market insights, supply chain strategies, sporting goods innovations, and mobility solutions. Suppliers can also book 20-minute slots to showcase their products, technologies, and expertise to gain extra visibility.

3 INNOVATION

Explore breakthrough technologies and processes transforming the industry!
Our forums spotlight pioneering projects that showcase tomorrow's solutions and tangible impact, setting new standards for efficiency and excellence.

A FULL PROGRAM

Key Sessions

1 Market Insights & Supply Chain Strategies

Explore key market figures, trends, and forecasts shaping Southeast Asia's evolving supply chain landscape. Understand Taiwan's strategic role as a key supplier in critical sectors such as automotive, semiconductors, and aeronautics. Gain insights into shifting supply chain dynamics, including optimization strategies and the relocation of manufacturing to Southeast Asia, driving new opportunities in the composites industry.

2 Sustainability & Circularity in Composites – Southeast Asia

This session explores how the composites industry in Southeast Asia is embracing sustainability and circularity. Experts will share innovations in bio-based and recycled materials, circular design, low-carbon processes, and regional recycling strategies. We'll also look at policies and collaborations driving change and highlight opportunities for sustainable growth in this dynamic market.

Stay informed with expert insights and interactive discussions on key topics shaping the future of the composites industry.

Event Format: Sessions feature a mix of keynote presentations, panel discussions, supplier-led workshops, and an Innovation Startups session to explore the latest advancements and real-world applications.

3 Sporting Goods & High-Performance Materials

Discover how advanced composite materials elevate durability, flexibility, and overall performance in sports equipment. From high-tech bikes and super shoes to cutting-edge rackets and golf shafts, see how manufacturing industries leverage these innovations for next-generation sporting goods.

4 Mobility & Lightweighting Solutions

From ground to space, advanced composite materials are transforming the future of mobility. Explore their impact on aircraft components, eVTOLs, lightweight LSEVs, and emerging new mobility solutions. See how Taiwan is driving innovation in lightweight engineering to enhance performance, efficiency, and sustainability across the transportation industry.

PARTICIPANTS PROFILE

To make sure our participants will connect with the best potential partners, this **Forum is reserved to its suppliers and buyers**. All participation is subject to accreditation.

BUYERS

OEM · TIER1 · Processors · End-users ·
Intermediate Products · Distributors
CEO · General managers · Procurement,
Engineers · R&D · Materials and sourcing
category specialists

SUPPLIERS

Large groups · Medium sized
companies · SMEs · Solution
Providers · Raw material producers ·
Fiber producers · Machines ·
simulation · Engineering companies ·
Mostly from Sales Department

BUYERS PROFILE

Buyers: Individuals who participate in the purchasing process of their company and who join the Forum to meet new suppliers, learn about new products & technologies.

100 Buyers will be invited by JEC to participate to JEC Forum Southeast Asia 2026.

Registered suppliers will have the opportunity **to select the buyers they would like to meet.**

Every Hosted Buyer will be committed to hold **at least 8 business meetings during the 2 days** of the Forum.

Top 5 Buyers Job Titles*

General Management: Managing Director / CEO

Engineering: Director / Manager / Engineer

Procurement and Purchasing: Director / Manager / Buyer

Research and Development: Director / Manager / Engineer

Materials: Director / Manager / Engineer

* In general on the JEC Forums

WHY PARTICIPATE AS A SUPPLIER

**2 FULL DAYS DEDICATED
TO BUSINESS**

- **Identify & connect** with your target buyers prior to the event to set meetings
- **Meet** with the buyers of the Southeast Asia
- **Develop** your business
- **Focus** on your ROI with our all-inclusive, easy to operate offers
- **Network** with your peers

! The registration to the **JEC Forum Southeast Asia as a supplier is limited to 50 suppliers**, for capacity and floor space reasons as well as to offer the adequate balance of buyers and suppliers.

BUSINESS MEETINGS PROGRAM

As a participant of the Forum, you have the opportunity to schedule **one to one business meetings ahead from the event**. Our platform allows you to schedule as many meetings as possible to maximise your ROI.

WHY REGISTER TO THE BUSINESS MEETINGS PROGRAM?

Save time and be efficient

- Identify the right business partners in the composites industry
- Optimise your time and agenda
- Benefit from the assistance of our teams, before, during and after the event

Enjoy 3 full days of networking opportunities and insightful content

BUSINESS MEETINGS SERVICE

INCLUDED IN YOUR REGISTRATION PACKAGE

Become a Supplier

- **By signing** the Supplier's contract.

Add

your staff members present

- **Fill out the contact** adding those who will be present onsite during the event.

• **Staff members** will receive an email with personal login credentials.

Complete

your personal profile

- **Finalise your personal profile** to ensure targeted meetings. Your profile will automatically link to your company profile.

• **Review your company profile**, the information provided on your contract will be inputted onto the platform for you.

Review

your inbound leads

- **Inbound leads showcases profiles of individuals** who have demonstrated interest, connected, or interacted with you, your team members, and/or your company profile.

• **Follow up;** there is high likelihood of converting this contact into a meeting.

Send and respond to meeting proposals

- **Send meeting proposals** to the Buyers or other Suppliers based on your targets.

• **Allow AI to recommend contacts** based on your profile and platform activity or use the filters to narrow down your search.

It's time to meet

- **Follow your business meetings agenda**, continue to schedule meetings and scan badges during the event.

Export the leads you generated

- **Leads consist of** accepted meetings, mutual profile interests and badges scanned.

• **(Profile and Contact Information)** Leads are also available in real time.

Continue the conversation

- **Follow up with your leads** after the event through your own tools.

• **(Email, Phone, Teams)**

YOUR SUPPLIER'S PACKAGE

limited to
50 companies

The suppliers' packages include a wide range of services such as:

- **A schedule of meetings with qualified buyers** looking for new suppliers and with precise needs and projects
- **A turnkey booth**, easy to operate, enabling you to focus on the business meetings opportunities
- A company presentation in the online platform to **present your products and services to the buyers**
- The opportunity to **present your company during a specific workshop**, integrated in the event's program

For your registered staff during the event as well as for your guests:

- **Full access to the event's content:** business conferences, keynotes and suppliers' workshops
- **Invitation to the Evening Networking Event**
- **All-inclusive food & beverage** service throughout the two days
- Free subscription to the JEC Composites Magazine
- Copy of the available speakers' presentations



**JEC FORUM
SOUTHEAST
ASIA 2026** Business
Meetings &
Conferences
June 23-24, 2026 TAIPEI
TAIWAN

Pictures from JEC Forum SEA 2024



JEC FORUM IN PICTURES

PACKAGE OFFERS

Conditions

STANDARD PACKAGE 4 sqm \$4,170 (tax included)

- 2 Supplier access passes
- Business Meetings Schedule with Pre-arranged Business Meetings
- Company listing on the suppliers' list (Website & Events Guide)
- Food & Beverage for your team & Guest (networking breaks & lunches during the two days of the Forum)
- All participants have access to the Evening Networking Event
- Access to the whole content of the event (including conferences and workshops)
- 1 Guest pass for your Customers, Prospects or Partners (including the networking breaks, the Evening Networking Event, the whole content, and Food & Beverage). This Guest Pass cannot be used by a member of your company
- **One 4sqm Booth, with power supply, signage & furniture (1 table & 4 chairs)**

PREMIUM PACKAGE 6 sqm \$5,360 (tax included)

- 3 Supplier access passes
- Business Meetings Schedule with Pre-arranged Business Meetings
- Premium visibility and advertising on the Business Meetings platform
- Company listing with logo on the suppliers' list (Website & Events Guide)
- Food & Beverage for your team & Guest (networking breaks & lunches during the two days of the Forum)
- All participants have access to the Evening Networking Event
- Access to the whole content of the event (including conferences and workshops)
- 1 Guest pass for your Customers, Prospects (including the networking breaks, the Evening Networking Event, the whole content, and Food & Beverage). This Guest Pass cannot be used by a member of your company
- **One 6sqm Booth, with power supply, signage & furniture (2 tables & 6 chairs)**

PACKAGE OFFERS

Booth layout

STANDARD PACKAGE
4 sqm Booth*

PREMIUM PACKAGE
6 sqm Booth*

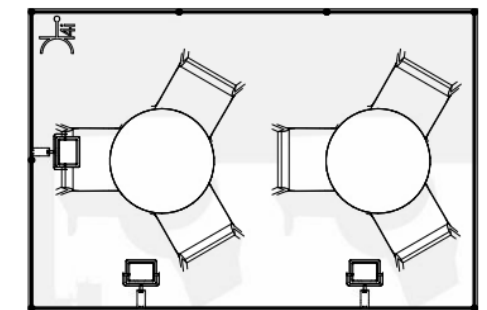
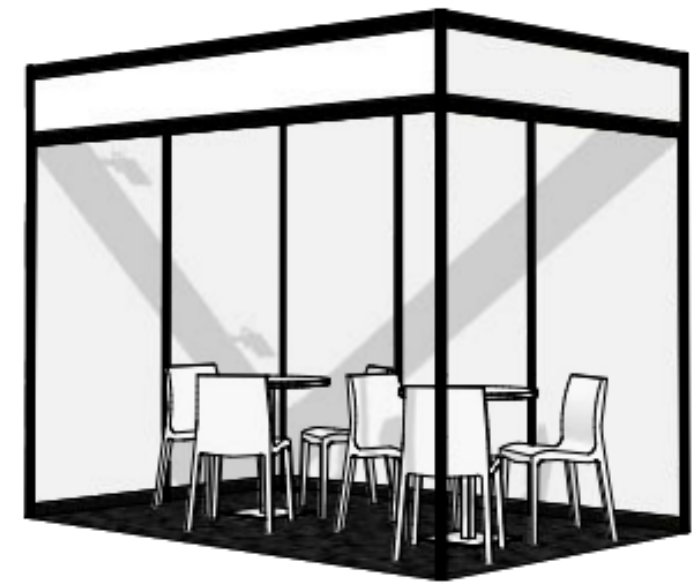
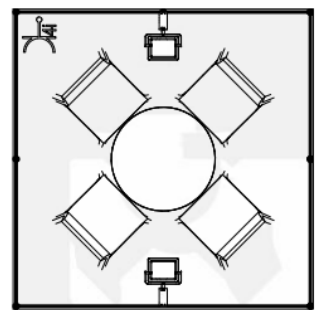

* Non contractual views

PACKAGE OFFERS

Booth layout

STANDARD PACKAGE
4 sqm Booth*

PREMIUM PACKAGE
6 sqm Booth*



FLOOR PLAN

The Premium Package offers extra visibility to the supplying companies

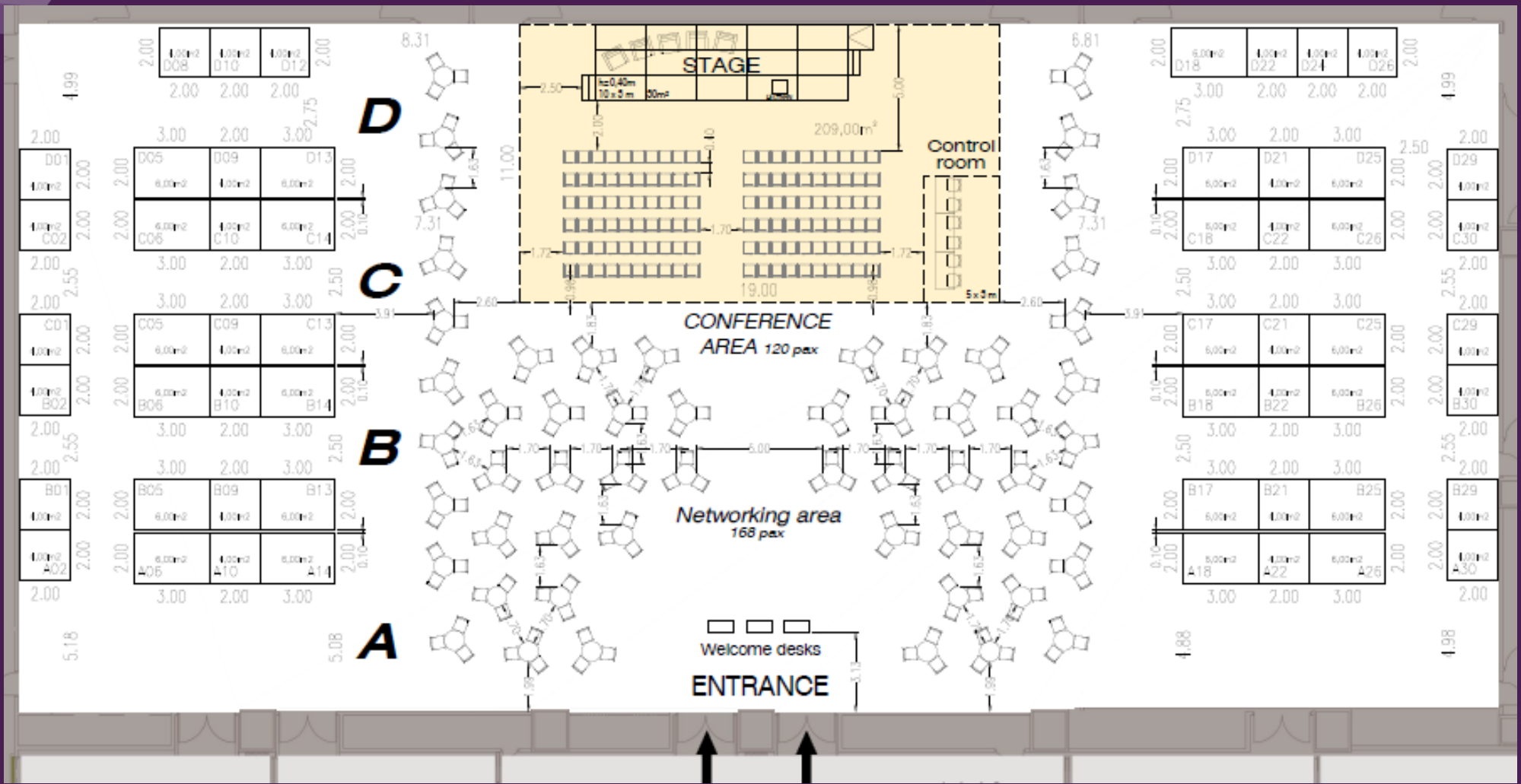



PREMIUM PACKAGE

The Premium Package offers extra visibility to the supplying companies

Company profile shown at the top of the Suppliers list

Company profile tagged as “Highlighted” on the Suppliers list

Company advertised on the Suppliers sidebar

Company profile highlighted on homepage

On average Premium Packages generate 4 more meetings and 33,5% more clicks

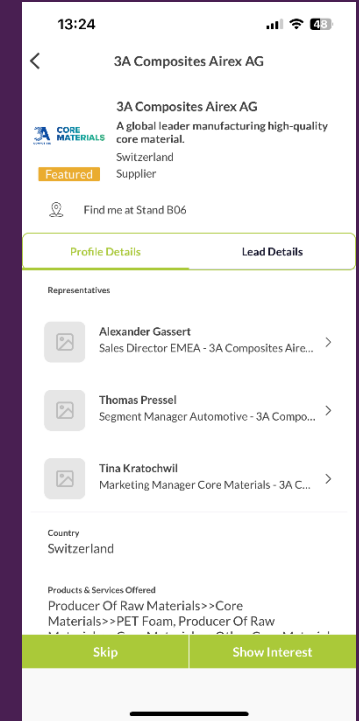
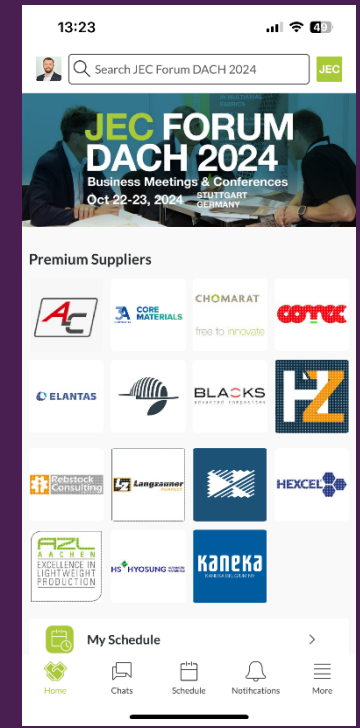

ADDITIONAL OFFERS

Sponsorship offers

Description	Price USD, tax included
Access badge Your logo printed on the back of the access badge	\$1,760
Badge holder lanyard Your logo printed on the show lanyards	\$1,760
Suppliers Workshops (Composites Exchange) 20 minutes to present your products and solutions to your customers	\$715
Additional Staff	\$605
Guest Pass	\$605
Registration of an Additional Co-supplier (1 pass + meetings)	\$1,210

ADDITIONAL OFFERS

MAIN SPONSOR
\$3,850 (tax included)

Gain maximum visibility and premium positioning as
the Main Sponsor of the event

- **Premium logo visibility** on all event communications: website, press releases, email blasts, event signage, and digital platform
- **Top placement** of your logo in the **Event Guide**, including cover page, welcome page, and program schedule
- **Brand visibility at key event locations** (welcome area, conference stage)
- **Logo on participant badges** and/or lanyards (optional, if no other sponsor)
- **1 dedicated page in the Event Guide** to showcase your company, products or initiatives
- Mention as **Main Sponsor** during opening session
- Possibility to distribute **flyers or branded giveaways** to all participants
- Priority access to **premium exhibition space**

ADDITIONAL OFFERS

SUSTAINABILITY SPONSOR
\$3,850 (tax included)

Position your brand as a key driver of sustainable innovation in the composites industry by sponsoring the dedicated sustainability program and exhibition area.

- Your **name associated with the Sustainability Conferences Session**
- Moderation of this Session and possibility to invite companies, startups, etc. as speakers
- **Logo visibility** on all communications related to the Sustainability Conferences (website, program, onsite signage)
- **Logo placement in the Event Guide**, next to the Sustainability Conferences in the schedule
- Recognition as **Sustainability Sponsor** in official event communications (press release, newsletter, website)
- Priority access to **premium exhibition space**
- Optional distribution of flyers or giveaways within the Sustainability Village

ADDITIONAL OFFERS

Evening Networking Event Sponsor \$2,500 (tax included)

- Your name in the Evening Networking Event name
- Visibility in the **Evening Networking Event invitation**
- Visibility in the **Event Guide**: logo next to the Evening Networking Event in the schedule of the Event Guide
- **Visibility onsite**: logos at the Reception location and flyers distributed on the tables
- Possible **distribution of flyers or goodies** to participants
- **5 entries to the Evening Networking Event**



ADDITIONAL OFFERS

- Your name in the F&B area where all participants network
- Visibility in the **Event Guide**: logo in the partners' section
- **Visibility onsite** on the Forum's signage: logo in the partners' section
- **Possible distribution of flyers or goodies** on the tables of the F&B area

F&B Sponsor
\$1,000 / day (tax included)
Limited to 2 Sponsors



CONTACT US TO BE PART OF IT

Lin ZHU (朱琳)
Business Development Manager
Greater China & ASEAN
zhu@jeccomposites.com

**JEC FORUM
SOUTHEAST
ASIA 2026** Business
Meetings &
Conferences

June 23-24, 2026 | TAIPEI
TAIWAN



**IN PARTNERSHIP
WITH:**



**Taiwan
Composites
Association**

WHY TAIPEI TAIWAN



Where Business Meets Innovation!

Taiwan is a global leader in **composite materials**, with a fully integrated supply chain that spans from advanced **fibers and resins** to cutting-edge **manufacturing technologies**.

With key players like **Formosa Plastics, Giant Bicycles, AIDC and Quest Composites**, Taiwan's composites industry is at the forefront of mobility, aerospace, sports, and sustainability.

The **JEC Forum Southeast Asia** is not just an event—it's a **highly curated Business Meetings platform**, designed to **connect buyers and suppliers**, foster new collaborations, and accelerate **market opportunities** in one of the most dynamic ecosystems in the world.

WHY TAIPEI TAIWAN



The Premier Hub for Composites Innovation

 **A cutting-edge, fully integrated ecosystem**
Taiwan is home to one of the most vertically integrated and diverse composite ecosystems in the world. From the development of fibers and resins to the advanced production of prepregs, components, and specialized equipment, the country is a key player in the global supply chain.

-  **Global industry leaders at the forefront**
- Formosa Plastics Group, Epotech, Farmao Tenlin, UHT, TEI, Formosa Taffeta, Swancor, SPCO (Resins, prepregs, blanks)
 - Giant Bicycles, Quest Composite, Advanced group (Mobility and sports)
 - EGAT, Arris, AIDC, Bonny, AMS (Aerospace)
 - Anderson, AMS, FARMAO (Manufacturing Equipment)
 - Thermolysis Carbon Waste Recycling (Sustainability and recycling)

-  **Strategic industrial clusters**
- Taipei: Headquarters, international access, innovation hubs
 - Hsinchu: Semiconductors, Energy, Innovation Centers
 - Taichung: Major industrial hub, advanced manufacturing, Aerospace, Sports Goods, Wind Energy
 - Taoyuan: Mobility, electronics, and high-precision composites, Aviation
 - Kaohsiung: Marine composites and sports applications

-  **A powerhouse of sustainable innovation**
- Startups ecosystem, Gogoro, Arris, etc.
 - With world-class universities and R&D centers, Taiwan is pushing the boundaries of composite technology, automation, and low-carbon solutions (MIRDC, PIDC, ITRI, TTA, IAPS, etc.)

WHY TAIPEI TAIWAN



Taiwan & Southeast Asia: A Strategic Connection

The gateway between Asia and the global composites industry
Taiwan plays a central role in the composite supply chain, bridging Asian, American, and European markets.

The transition gateway between Mainland China, North Asia and Southeast Asia

🔥 A natural link with JEC Forum Bangkok 2024

- Bangkok 2024: ASEAN hub, focus on regional composite applications
- Taipei 2026: Technological and industrial innovation hub with a more advanced ecosystem

🌐 Strengthening strategic partnerships

- Increasing exchanges between Taiwan and Southeast Asia
- Collaboration with local and international composite industries

🚀 A launchpad for the future of composites

The JEC Forum SouthEast Asia 2026 in Taipei will be the epicenter of innovation, business meetings, and strategic opportunities for the entire industry.